

Erik Thomassen

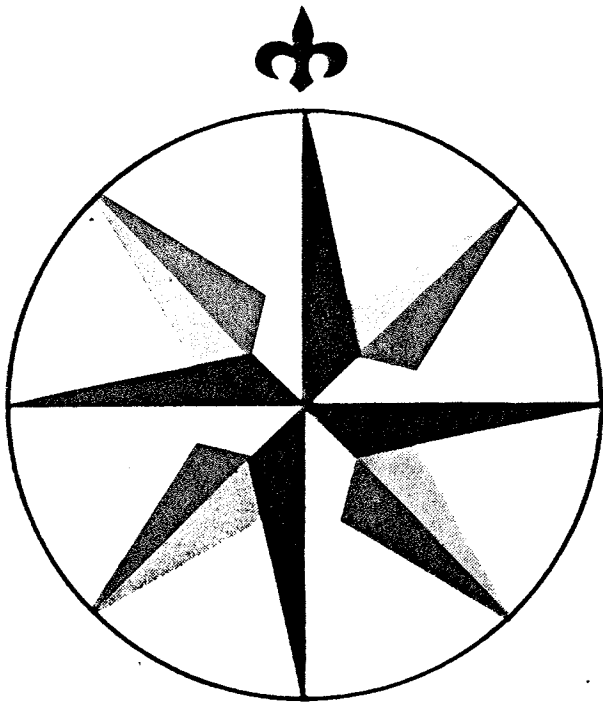

Sailor

Sailor

INSTRUKTIONSBOG FOR
SAILOR R 110

INSTRUCTION BOOK FOR
SAILOR R 110

INSTRUKTIONSBUCH FÜR
SAILOR R 110

INSTRUCTIONS POUR
SAILOR R 110

INSTRUCCIONES PARA
SAILOR R 110



A/S S. P. RADIO · AALBORG · DENMARK

CONTENTS

A. Operation	
I: Introduction	2
II: Controls	3
III: General Broadcasting	4
IV: Fixed Frequencies	4
V: Telegraphy and Consol Signals	4
VI: Reception of General Radio Beacon	4
B. Reception of Consol Signals	
I: Description of the Consol Direction-finding System	6
II: Details of Stavanger and Bush Mills Radio Beacons	7
III: Consol Chart	8
C. Taking Bearings of General Circular Radio Beacons	
I: Principle	9
II: Sources of Errors	9
III: Wave Types	11
IV: Selecting a Direction Finder	11
V: Direction-finding using Conventional Permanently Installed Radio Direction Finder	12
VI: Direction-finding using the SAILOR type BK171 Ferrite-Navigator	13
D. Installation	
I: Aerial and Earth Wire	14
II: Inserting Crystals	15
III: Connection of DF-equipment	15
IV: Supply Voltage	15
V: Loudspeaker	15
VI: Other Connections	16
VII: Noise and Interference in the Receiver	16
E. Service Information	
I: Technical Data	17
II: Description of Circuits	17
III: Layouts, Dimensional Outlines and Circuit Diagrams	22

A

A. Operation

I. Introduction:

The SAILOR R110 is a radiotelephony receiver with 35 crystal-controlled channels for reception of AM (A3, A3H) and SSB (A3A, A3J) in the range 1.6–9 MHz. The 35 crystal-controlled channels are distributed as follows:

23 in the range 1.6–4.2 MHz

12 in the range 4.0–9 MHz

The SAILOR R110 also incorporates a tunable AM receiver for broadcast reception and direction finding on the following frequency bands:

LW 150– 290 kHz

NW 280– 600 kHz

MW 600–1650 kHz

SW 1600–4500 kHz

B

The SAILOR R110 features the same modular construction as SAILOR models R103, R104, R105 and R106.

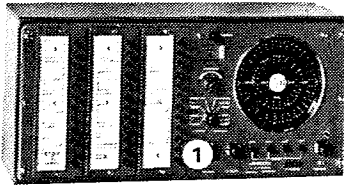

- 1** **AF-GAIN**
with main switch. Controls the audio output.

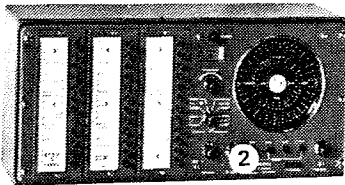

- 2** **RF-GAIN**
Regulates the amplification of RF stage and IF amplifier.

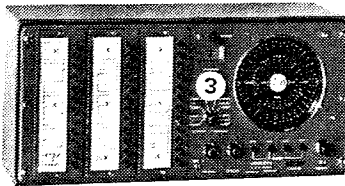

- 3** **CLARIFIER**
Corrects for small frequency errors in SSB signals. To be set for clearest reception of SSB signals.

FUNCTION SWITCH

This switch is divided up in a TELEPHONY section and a NAVIGATION section, each with four positions.

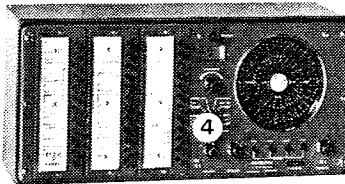

- 4** The telephony section switches between SSB reception and AM reception without AGC and SSB reception and AM reception with AGC. The navigation section switches between A₁ and A₂ reception via the normal receiver aerial for tuning in stations and via the DF-equipment.

B

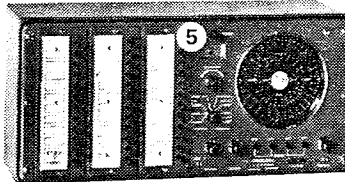

- 5** **METER and DIMMER**
The meter shows the signal strength of the received signal and the dimmer is for regulation of dial light.

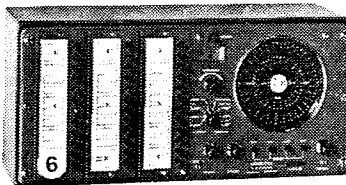

- 6** **BANDS**
When the button is pressed, the built-in tunable receiver is put into operation. If one of the other buttons in the row(s) is pressed, the fixed frequency in question will automatically be switched in.

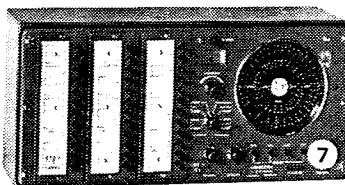

- 7** **STATION INDICATOR (TUNING)**
The dial is calibrated in kHz.

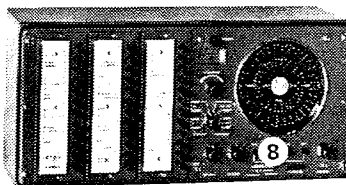

- 8** **ROW OF PUSH-BUTTONS BANDS, tunable receiver:**
Reception on aerial or DF-equipment.
- | | | | |
|----|--------------|----|---------------|
| LW | 150– 290 kHz | MW | 600–1650 kHz |
| NW | 280– 600 kHz | SW | 1600–4500 kHz |

III. General Broadcasting

1. Switch on the receiver by turning AF GAIN clockwise (1).
2. Press button marked BANDS in the row of push buttons to the extreme left of the receiver (6).
3. Set sensitivity control RF GAIN to max. (2).
4. Set the function switch to position AM AGC-ON (4).
5. Select desired range by pressing one of the four push-buttons marked BANDS (8).
6. When the desired station has been located on the dial, tune for maximum meter deflection (7).
7. The volume is controlled by means of the volume control, AF GAIN.

IV. Fixed Frequencies

1. Switch on the receiver by turning AF GAIN clockwise (1).
2. Set the sensitivity control, RF GAIN, to max. (2).
3. Select desired kind of reception, AM AGC-ON or SSB AGC-ON, by means of the function switch (4).
4. Press the push-button marked with the desired frequency.
5. If the received signal is SSB, turn CLARIFIER (3) for clearest reception.
6. The volume is controlled by means of AF GAIN.
7. When receiving SSB signals turn RF GAIN (2) as far as possible anti-clockwise without weakening the received signal. (This applies only to powerful signals).

V. Telegraphy and Consol Signals

(See also Description of the Navigation Section).

1. Switch on the receiver by turning AF GAIN clockwise (1).
2. Press button marked BANDS in the left push-button row of the receiver (6).
3. Set the sensitivity control, RF GAIN, to max. (2).
4. Set the function switch to A_2 -ANT (4).
5. Select range by pressing one of the push-buttons marked BANDS (8).
6. When the desired station has been located (use the triangular frequency marks on LW and NW) tune for max. meter deflection by means of TUNING (7) and for suitable deflection by means of AF GAIN (1).
7. If the received signal is unmodulated A_1 , set function switch to A_1 -ANT position (4).
8. If the received signal is A_1 , and is disturbed by noise from the rigging etc., it will be advantageous to turn AF GAIN to max. and tune the volume by means of RF GAIN. As to Consol Signals see special section.

VI. Reception of General Circular Radio Beacons

1. Set for the desired station as described under V.
2. If the received signal is unmodulated, set the function switch to A_1 -LOOP position. If the received signal is modulated, set the function switch to A_2 -LOOP position.

3. Select wave range (same as on receiver) on the ferrite-navigator or on the transformer box of the DF LOOP.
Tune by means of the TUNE knob on the ferrite-navigator (transformer box) for max. meter deflection (volume). Volume of signal is tuned by means of RF GAIN.
4. Turn DF aerial for minimum volume or for minimum meter deflection.
5. Repeat 4 by increased sensitivity (RF GAIN) until a sharp null has been achieved.
6. Read the graduated scale of the DF equipment and make a note of the result (see section C for further details).
7. If necessary make sense determination by means of the SENSE knob on the DF equipment. For further particulars see instruction manual for the DF equipment in question.

Description of the Navigation Section

The left half of the function switch with four positions marked A₂-ANT, A₂-LOOP, A₁-ANT and A₁-LOOP has very special functions which make direction finding simple and logical. The functions of the individual switch positions are tabulated below.

FUNCTION					
POSITION	B.F.O.	Filter	A.G.C.	Meter reading	AF filter
SSB AGC OFF	ON	SSB	OFF	AGC	OFF
AM AGC OFF	OFF	AM	OFF	AGC	OFF
SSB AGC ON	ON	SSB	ON	AGC	OFF
AM AGC ON	OFF	AM	ON	AGC	OFF
A2-ANT	OFF	Narrow Bandwidth	ON	AF	OFF
A2-LOOP	OFF	Narrow Bandwidth	OFF	AF	OFF
A1-ANT	ON	Narrow Bandwidth	ON	AF	ON
A1-LOOP	ON	Narrow Bandwidth	OFF	AF	ON

The following SAILOR direction-finding equipment can be used in combination with the R 110 receiver.

SAILOR ferrite-navigator BK171.

SAILOR DF-LOOPS 26 F and 26 FA.

When SAILOR DF-LOOPS are used, a SAILOR transformer box FB175 must also be used.

For further particulars see our special brochure.

B. Reception of Consol Signals

I. Description of the Consol Direction-finding system

The following should be taken only as an introduction to the Consol direction-finding system. For additional information about the subject reference should be made to the publications issued by the proper government authorities.

Using the Consol direction-finding system it is possible to determine one's exact position, provided the approximate position is known, by taking cross bearings of two Consol radio beacons with the SAILOR R110.

A Consol beacon consists of a circular beacon which transmits the beacon's call sign and a continuous signal, and a directional beacon which transmits different signals in different directions. Transmissions take place alternately as specified in »Details for Stavanger and Bush Mills Consol Radio Beacons«. The circular transmission serves for tuning the receiver to the wanted beacon, as to a general telegraphy station, see Section V of Chapter A. Below is shown a chart with two stations, Stavanger and Bush Mills, of special interest in the North Sea and North Atlantic. For each of the two stations is indicated the moments at which transmissions of the directional beacons start. These transmissions consist of sectors. Every second sector (the A sectors) comprises 60 dots; the other sectors (the B sectors) consist of 60 dashes. These signals are transmitted for a period whose length is indicated on the chart. The dividing lines between sectors are indicated as »beams«. Along each beam, dots and dashes unite into a continuous signal. The sectors rotate in the directions of the arrows at the uniform speed of exactly one sector-width during the time a transmission from a directional beacon is in progress. Hence, from the position marked X in the North Sea you will hear from the Stavanger Consol radio beacon first 48 dots until the »S« beam passes by, then 12 dashes, ending the transmission. This is followed by a circular transmission etc. etc. From Bush Mills, you will first hear 28 dashes until the passage of the »BM« beam, after which 32 dots will be heard. It will then be easy, using the quite simple diagrams issued by the proper government authorities, to determine the exact bearings of the Consol beacons as the diagrams give the bearing in degrees corresponding to the number of dots and dashes heard since the moment the directional transmission started.

Near the beams, since these are not sharply defined, a number of dots and dashes will not be heard, or heard only indistinctly. Accordingly, you count all dots and dashes during a transmission period. If you count, say a total of 54 dots and dashes it means that $60 - 54 = 6$ characters have been lost. This number you divide into 3 dots and 3 dashes and add these to the number counted. You now have the figure to be used for plotting on the diagram.

Maximum bearing accuracy is obtained near the beam centre, where it averages $\pm 0.2^\circ$, decreasing as the ambiguous sectors are approached. In sectors bordering on the ambiguous sectors, errors of $\pm 0.5^\circ$ by day and $\pm 1.5^\circ$ by night must be expected. Bearings should not be taken in the ambiguous sectors and less than 25 nautical miles from Consol radio beacons.

II. Details for Stavanger and Bush Mills Consol Radio Beacons:

Stavanger:

Position: 58°, 37', 32" N. 5°, 37', 49" E.

Frequency: 319 kHz (940 m).

Call sign: LEC

Signal: A. General circular transmission.

- 1. Letters LEC 6 sec.
- 2. 1 long dash 50 sec.
- 3. Pause 3 sec.

B. Directional transmission.

- 1 dot or dash every second 60 sec.
- Pause 1 sec.

Total duration of each transmission period is therefore 120 sec.

Transmitting schedule: Round the clock. – Range: approx. 850–1300 nautical miles.

Bush Mills:

Position: 55°, 12', 20" N. 6°, 28', 0.2" W.

Frequency: 266 kHz (1128 m).

Call sign: MWN _ _ _ . _ _ _ . _ .

Signal: A. General circular transmission.

Continuous transmission interrupted by call sign 30 sec.

B. Directional transmission.

1 dot or dash every 0.5 sec. 30 sec.

Total transmission period 60 sec.

Transmitting schedule: Round the clock except between 15:00 and 15:15 GMT.

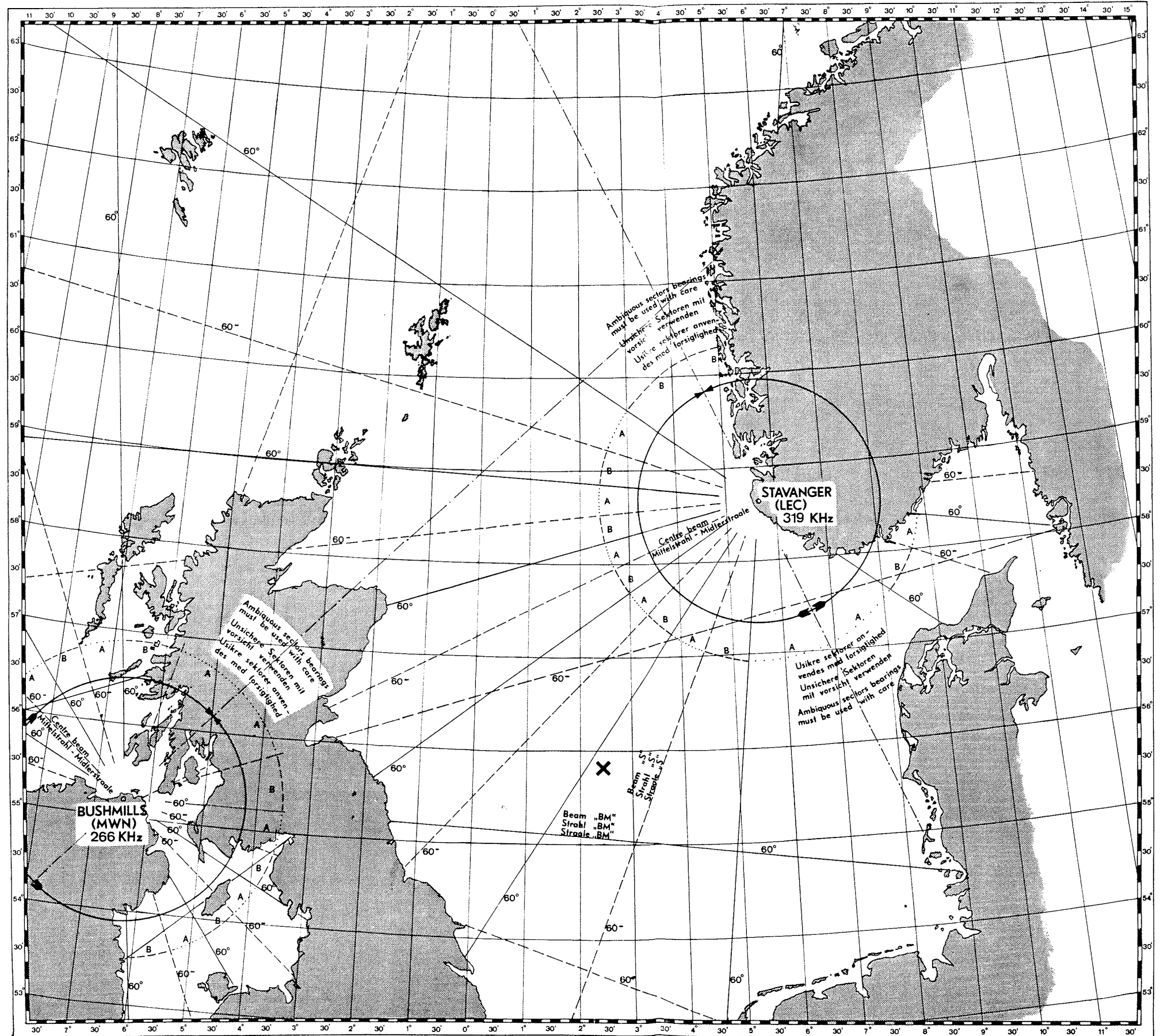

C. Taking Bearings of General Circular Radio Beacons

I. Principle:

Determining one's position by direction finding is done by taking compass bearings of not less than two, preferably three or four radio beacons of known geographical locations. These compass bearings are plotted on a chart (bearing-lines), and their intersection point indicates the position of the vessel.

Compass bearings are taken by means of a direction finder connected to the receiver. A direction finder can take various forms but always comprises a directional aerial and one or more dials calibrated in degrees. When the direction finder is rotated, the signal strength will be dependent on the angle between the direction-finding aerial and the direction to the beacon. If rotated 360° , the direction finder will pass through two maxima and two minima. The two minima, which are spaced 180° apart, are better defined than the maxima and are therefore employed for direction finding. Consequently, using the direction finder you can determine the exact direction to the beacon, reading the direction on the graduated dial either as an angle relative to the vessel's center line (in which case the angle is called the relative bearing) or as an angle relative to north (the compass bearing).

If the direction finder gives the relative bearing, the compass bearing can be found by adding the relative bearing to the compass course.

On SAILOR direction-finding loops, this addition can be done by setting another graduated dial according to the compass course.

As stated above, two minima will be found on rotating the direction finder 360° , and only one of these minima is the correct one, the other being 180° opposite. However, using the sensing device of the direction finder you can determine which minimum is the correct one. This operation is known as sense determination and is described in detail in the sections covering the individual direction finders.

Direction finding can be done on all bands (BANDS). However, a certain amount of inaccuracy should be expected when taking bearings of stations other than actual radio beacons. The reason is that radio beacons are built and set up with special attention being given to their application.

The fundamental principle when setting the receiver for taking bearings of one or more stations transmitting on the same frequency is first to tune the receiver to the station on the general aerial, thereafter switching to the direction-finding aerial and doing the actual direction-finding job.

The old saying that practice makes perfect applies here too. You cannot expect good results without previous training.

It is therefore very important to practise the procedure described in item V or VI (depending on the type of direction finder employed) under good weather conditions at a known position.

II. Sources of Errors:

The following factors are possible causes of errors in radiolocation work:

1. Magnetic variation.
2. Local compass error.
3. Local radio direction-finding error.
4. Coastal refraction.
5. Night effect.

To determine the compass bearing of a beacon by means of the radio direction finder, the compass course is used as starting point as described in the preceding section, bearing in mind that:

True course = compass course (read course) + variation + local compass error.

The variation is taken from a chart, and the local compass error from the local compass error table in the usual manner.

The local radio direction finder error is due to the action of the vessel's metal parts such as rigging, mast, hull etc. It is dependent on the location of the direction-finding aerial on the vessel and on the angle of the bearing relative to the vessel's center line.

Hence bearings should always be taken from the same place on the vessel. Also, a correction table should be drawn up for the direction finder operated in that particular place.

To make such a table, the vessel is swung near a radio beacon within optical sight, finding at every 10° or so the difference between optical relative bearing and radio relative bearing.

Coastal refraction may occur where beacon signals must travel partly over land and partly over the sea to reach the vessel or if they leave the shore at a very acute angle.

The use of radio beacons should therefore be avoided where these possibilities of errors exist.

Night effect is a bearing error due to intermixing of radio signals reaching the receiver along the surface of the earth and radio signals arriving after having been reflected from the ionosphere. This effect is especially in evidence at night, in particular from one hour before to one hour after sunset and sunrise, and manifests itself as flattening and/or »creeping« of minima. The night effect also varies with the seasons, and is dependent on the geographical position, being smallest at the equator. Under such conditions it is advisable to employ beacons that are as near the vessel as possible and to employ bearings with some caution. If more than one frequency is available, the lowest should as a rule be preferred. This will provide maximum bearing accuracy with a minimum of disturbance from fading and night effect.

Example of Correction Table for Radio Direction Finder:

Read Relative Bearing	Correction	Read Relative Bearing	Correction
0°	0	190°	+1
10°	+2	200°	+3
20°	+4	210°	+5
30°	+6	220°	+7
40°	+7	230°	+8
50°	+7	240°	+9
60°	+7	250°	+8
70°	+6	260°	+7
80°	+4	270°	+5
90°	+2	280°	+2
100°	0	290°	0
110°	-2	300°	-3
120°	-4	310°	-4
130°	-5	320°	-4
140°	-5	330°	-4
150°	-4	340°	-3
160°	-3	350°	-2
170°	-1	360°	0
180°	+1		

$$\text{Correction} = \text{Optical relative bearing} - \text{read radio relative bearing}$$

III. Wave Types (types of transmission)

The R110 is designed for the reception of four different wave types:

A_0 : Constant unmodulated carrier. This wave type can be received only on receivers which are equipped with a beat-frequency oscillator (BFO). (The BFO converts the unmodulated signal so that it can be perceived acoustically).

The A_0 signal is excellently suited for taking bearings but has the considerable drawback that station identification is difficult (all stations sound the same).

A_0 occurs rarely in radio direction finding.

A_1 : Unmodulated telegraphy. Morse characters are produced by turning an unmodulated carrier on and off. Reception of such a carrier requires a BFO.

A_1 occurs rarely in radio direction finding.

A_2 : Modulated telegraphy. Morse characters are produced by interrupted tone modulation on a constant carrier (less often both modulation and carrier are interrupted simultaneously).

A_2 is generally received without a BFO, but use of the BFO can be an advantage under certain conditions.

A_2 is without comparison the most widely used wave type for radio beacons.

A_3 : General broadcasting and AM telephony.

The carrier is modulated with music or speech.

A BFO is not normally used for reception of this wave type. However, using a BFO will often be advantageous if it is desired to take the bearing of an A_3 signal.

A_3 is never used by actual radio beacons.

IV. Selecting a Direction Finder

Two types of direction finder are available for the SAILOR R110.

1. SAILOR BK171 Ferrite Navigator

This direction finder is specially suited for use in small boats of plastic or wood.

Advantages of this equipment are simple operation, modest space requirements, simple installation, insensitivity to heeling (sailing boats), and a fixed-mounted sense aerial.

The BK171 is not suited for use in metal vessels.

2. Permanently Installed Loop

SAILOR 26F/FB175 or

SAILOR 26FA/FB175.

This type of equipment should be chosen for larger, spacious vessels and for fishing craft and coasters.

These direction finders are more difficult to install and operate than the Ferrite Navigator, but if used by a skilled operator and the vessel can be kept on a stable course while bearings are being taken it will provide somewhat better accuracy than is possible with the BK171 Ferrite Navigator.

V. Direction-Finding Using Conventional Permanently Installed Radio Direction Finder

1. Apply power to the receiver by turning the volume control (AF-GAIN) clockwise.
2. Set FUNCTION switch to A₂-ANT (if wave type used by beacon is A₀ or A₁, use A₁-ANT).
3. Depress proper button in row marked BANDS.
4. Set sensitivity control (RF-GAIN) to maximum.
5. Set dial to beacon frequency. When beacon is heard, retune for max. volume. Adjust volume control (AF-GAIN) for convenient sound level and meter reading (approx. half scale). Do not touch AF-GAIN during remainder of direction-finding procedure.
6. Switch from conventional aerial to direction-finding aerial by turning the FUNCTION switch one step anti-clockwise (e.g. from A₂-ANT to A₂-LOOP).
7. Select on the Transformer Box the wave band corresponding to the receiver setting and rotate the TUNE knob of the direction-finding equipment for maximum volume.
8. Rotate the sensitivity control (RF-GAIN) so that meter reads half scale.
9. Repeat items 7 and 8.
10. Set the loose graduated disc so that 360° is against the red pointer.
11. Rotate the Direction Finder until a minimum is obtained.
A minimum is indicated either by minimum signal in the headphones or speaker, or by minimum receiver meter reading. Lock the Direction Finding Loop, using the grub screw, and note down *true* compass course at the moment the bearing is taken.
12. Read the relative bearing against the blue pointer, and read in the Direction Finder's correction table the amount of correction corresponding to that relative bearing.
13. Add the correction found under item 12 to the *true* compass course noted down under item 11 and rotate the plexiglass dial until the red pointer is against the degree number found by the addition.
14. Read, against the blue pointer, the *true* radio compass bearing.
15. If required, the sense-direction can be found by rotating the direction-finding loop approx. 90° anti-clockwise (90° opposite sun). If the volume (meter reading) increases when the SENSE button is pressed, the radio compass bearing found under item 14 is the course *towards* the radio beacon whereas decreasing signal strength indicates that the course is *away* from the beacon.

Example

A bearing of the Hals Barre Beacon, Denmark, is required. The following data apply to this beacon:

Transmitting frequency: 310.3 kHz.

Wave type: A₂.

Transmitting schedule: hour + 1 min., hour + 4 min., hour + 7 min.

Identification signal: Morse code for HB: -

- a. Tune the receiver and direction finder to 310.3 kHz as described under items 1 to 10 inclusive.

- b. Wait until the Morse code for HB are heard (several beacons transmit on the same frequency).
- c. Perform item 11.
True compass course is noted down as being 270° (found as read compass course + variation + local compass error).
- d. Perform item 12.
Relative bearing is read against the blue pointer as being 90° . The correction for the direction finder is found by connecting 90° in the table with $+ 2^\circ$.
- e. Set, by rotating the plexiglass dial, the red pointer against $270^\circ + 2^\circ = 272^\circ$ (item 13).
- f. Read, against the blue pointer, the true radio compass bearing as being 2° .
- g. Perform sensing as described under item 15.
The signal strength decreases when the SENSE button is pressed. The true radio compass bearing read under item f is therefor the course away from the beacon.
(The course *towards* the beacon is $180^\circ + 2^\circ = 182^\circ$).

VI. Direction-Finding Using the SAILOR Type BK171 Ferrite Navigator

1. Apply power to the receiver by turning the volume control (AF-GAIN) clockwise.
2. Set FUNCTION switch to A_2 -ANT (if wave type used by beacon is A_0 or A_1 , use A_1 -ANT).
3. Depress proper button in row marked BANDS.
4. Set sensitivity control (RF-GAIN) to maximum.
5. Set dial to beacon frequency. When beacon is heard, retune for max. volume. Adjust volume control (AF-GAIN) for convenient sound level and meter reading (approx. half scale). Do not touch AF-GAIN during remainder of direction-finding procedure.
6. Switch from conventional aerial to direction-finding aerial by turning the FUNCTION switch one step anti-clockwise (e.g. from A_2 -ANT to A_2 -LOOP).
7. Select on the Ferrite-Navigator the wave band corresponding to the receiver setting and rotate the TUNE knob of the direction-finding equipment for maximum volume.
8. Rotate the sensitivity control (RF-GAIN) so that meter reads half scale.
9. Repeat items 7 and 8.
10. Rotate the Ferrite Navigator until a minimum is obtained. A minimum is indicated either by minimum signal in headphones or speaker, or by minimum receiver-meter reading.
A sharper minimum can be obtained by readjusting RF-GAIN.
11. The magnetic radio compass bearing of the beacon can now be read directly in the prism of the bearing compass. (True radio compass bearing is obtained by adding the variation to the read compass bearing).
12. If necessary, the sense-direction can be found by rotating the Ferrite Navigator approx. 90° anti-clockwise and pressing the SENSE button (be sure to install the sense aerial).
If the volume (meter reading) decreases when the SENSE button is pressed, the radio compass bearing found under item 11 is the course *towards* the beacon whereas increasing signal strength is an indication that the course is *away* from the beacon.

NOTE: It is important that the meter reads approx. half-scale before pressing SENSE button (adjust with RF-GAIN).

When using a Ferrite Navigator, local compass error and local radio direction finder error are not usually taken into account.

These correction factors are as a rule small in plastic and wooden boats if regard is paid to the factors covered by Section II of Chapter C.

The correction for variation referred to under item 11 may also be omitted if consistent use is made of the magnetic compass rose of the chart in fixing one's position.

Example

A bearing of the Hals Barre Beacon, Denmark, is required. The following data apply to this beacon:

Transmitting frequency: 310.3 kHz.

Wave type: A₂.

Transmitting schedule: hour + 1 min., hour + 4 min., hour + 7 min.

Identification signal: Morse code for HB: - . . .

- a. Tune the receiver and Ferrite Navigator as described in items 1 to 9 inclusive.
- b. Wait until the Morse code for HB are heard (several near-by beacons transmit on the same frequency).
- c. Perform item 11.
Magnetic radio compass bearing is read as being 180°.
- d. Perform sensing as described under item 12.

The signal strength decreases when the SENSE button is pressed.

Result

Magnetic course towards the beacon = 180°.

To obtain true course, add the variation (of the chart) to the found value of 180°.

D. Installation

I. Aerial and Earth Wire:

The wire aerial plugs into the single-pole coaxial socket placed on the rear of the receiver. For aerial use a 5–20 m long wire or whip aerial minimum 4 m placed as high and as much in the clear as possible. For the lead-in from the aerial use a good quality coaxial cable, ET10M or similar. It is important that the lead-in is as short as possible and that it is not laid near other electric cables. All joints should be made by soldering.

Connect the earth wire to the chassis-screw on the rear of the receiver.

The earth wire, insulated copper cable not less than 2,5 sq. mm. thick, should be connected to the hull (in iron vessels) or through a broad copper-band to the keel bolt or (in wooden vessels) to a metal plate not less than one sq. m. in size on the outside of the hull below the water line. The earth wire should be as short as possible. A good earth connection is of decisive importance for low-noise reception and a sharp bearing null. See also our special information sheet covering installation procedures.

When the receiver has been installed, the aerial must be tuned. This is done by means of the aerial trimmer (AERIAL TUNE) placed behind the crystal cover to the extreme left on the front panel of the receiver for the frequency range 1.6–4.2 MHz; and, behind the crystal cover at the far right, for the frequency range 4–9 MHz.

For tuning use the following procedure:

1. Set the receiver for listening on a push-button channel as described under IV of section A (preferably in the middle of the range 1.6–4.2 MHz (or the range 4–9 MHz as the case may be)).
2. Turn the aerial tune by means of an *insulated* trimming stick for max. volume of signal or noise (max. meter deflection).

II. Insertion of Crystals:

1. Take off the cover(s) on the front of the receiver and insert the crystal in the crystal holder concerned. For the frequency range 4–9 MHz in the crystal section at the far right, and for the frequency range 1.6–4.2 MHz in the two other crystal sections.
2. Connect a frequency counter with min. sensitivity 0.5 V pp and a frequency accuracy of min. one part per million to the terminal marked COUNTER placed behind the crystal cover to the extreme left on the front panel of the receiver for the frequency range 1.6–4.2 MHz; and, behind the crystal cover at the far right, for the frequency range 4–9 MHz.
3. Press the push-button concerned and align, by means of the trimmer placed opposite to each crystal, for the frequency stamped on the crystal (reception frequency + 600 kHz).
4. The receiver's R.F. circuits are adjusted to maximum sensitivity by means of the metal adjusting screws adjacent to each crystal, using the following procedure:
 - A. Unscrew the adjusting screw (anti-clockwise) until the top of the screw levels with the front panel.
 - B. Turn RF-GAIN control fully clockwise (max.). Select AM, AGC-ON mode with function switch. Set AF-GAIN to suitable volume of noise or signal.
 - C. Screw the adjusting screw inwards (clockwise) until peak output of signal is obtained (max. meter reading).

N.B. The correct peak is the first obtained when screwing inward, otherwise the receiver will be tuned to an image frequency.

III. Connection of DF-equipment:

Any kind of DF equipment must be connected by means of an intermediate cable to the socket J1002.

J1002 is the lower of the 2 multi-sockets on the rear of the receiver.

IV. Supply Voltage:

The receiver can be supplied with either a 110/220 V AC or 12/24 V DC power supply unit.

Switching between 110/220 V AC and 12/24 V DC respectively is effected by means of a sliding switch on the rear of the receiver.

V. Loudspeaker:

An external loudspeaker, if required, should have an impedance of 4–8 ohms.

A

VI. Other Connections:

All connections apart from earth and aerial must be made through the intermediate cable from the transmitter.

The intermediate cable is provided with a multiplug, which is to be inserted in the uppermost multisocket on the rear of the receiver.

Connection cable between transmitter and receiver.

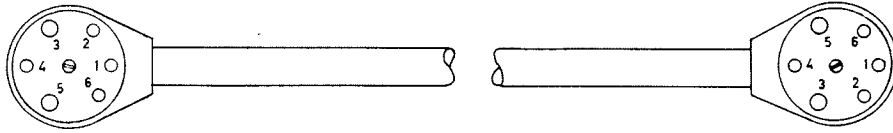

RECEIVER PLUG FEMALE
HIRSCHMANN TYPE MeK 60z

- PIN 1 - LOUDSPEAKER - VIOLET
- PIN 2 - TO RX. BANDS SECT. - WHITE
- PIN 3 - 24 V.D.C. POSITIVE - RED (BUHR)
- PIN 4 - COMMON - BROWN
- PIN 5 - 24 V.D.C. NEGATIVE - BLACK
- PIN 6 - A F OUTPUT FROM RX. BLUE (BUHR)
- PLUGS VIEWED FROM PIN SIDES

TRANSMITTER PLUG MALE
HIRSCHMANN TYPE MeS 60z

Connection cable when only receiver is used.

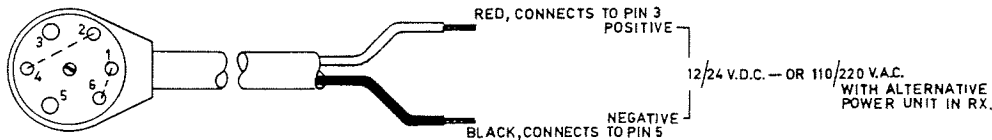

RECEIVER PLUG FEMALE
HIRSCHMANN TYPE MeK 60z
VIEWED FROM PIN SIDE

- PIN 1, STRAPPED TO PIN 6, INSIDE PLUG
- PIN 2, STRAPPED TO PIN 4, INSIDE PLUG

A

VII. Noise and Interference in the Receiver:

The effective range obtained with a radiotelephone depends first and foremost on the aerial and the earth connection. The better the receiver aerial, i.e. the higher and the more in the clear, and the shorter and more direct the earth connection the longer the range and the less undesired noise and interference.

Interference may be grouped as follows:

1. Atmospheric, i.e. electrical discharges. This noise is a natural phenomenon and consequently cannot be eliminated. If there is thunder in the air, crackling will be heard in the radio. The influence of rain, hailstorms and static discharges may be reduced by providing the best possible insulation of the receiver aerial.
2. Man-made noise. This interference can be produced by engines, dynamos, echo sounders, radar etc. and can only be remedied by effective suppression at the noise source. Generally your service agent should be able to advise you how to deal with possible radio interference. But should the problem be a little more tricky, it would be advisable to consult a specialist in this field.
3. Rigging-noise, which may originate from poor electrical connections between shackles, thimbles, in short all metallic parts with varying electrical connection. Sometimes the propeller shaft may produce noise if for instance the connection to stern tube or machinery is unreliable.

In general, a good, well positioned receiver aerial and a good, short earth connection will help in reducing interference level.

E. Service Information

I. Technical data:

PRESS-BUTTON-CHANNELS

1.6–9 MHz.

Frequency range:

23 channels in the range 1.6–4.2 MHz.

12 channels in the range 4–9 MHz.

Crystal frequency: Received frequency + 600 kHz.

Frequency stability:

Short time stability ± 20 Hz

Long time stability ± 100 Hz

Selectivity:	SSB	AM
6 dB band width	>2.4 kHz	>6 kHz
60 dB band width	<4 kHz	<20 kHz

Sensitivity:

S/N = 10 dB better than	1.5 μ V	4.5 μ V
IF-attenuation		90 dB
Image-attenuation	80 dB at about	2.5 MHz
Audio output		max. 5 W

TUNABLE AM-RECEIVER:

Sensitivity:

For all ranges better than 5 μ V

Frequency ranges:	LW:	150– 290 kHz
	NW:	280– 600 kHz
	MW:	600–1650 kHz
	SW:	1600–4500 kHz

Direction Finding on all ranges.

Audio output: 5 W

Power supply:

The receiver is available with one of the following power supplies:

12/24 Volt DC

110/220 Volt AC

Intermediate frequency:

600 kHz.

II. Circuit Description for SAILOR R110:

Generally:

The SAILOR R110 is fully transistorised and, like SAILOR receivers R103, R104, R105 and R106, built in functional units, providing a high order of basic construction uniformity in all models.

The mode of construction appears clearly from the block diagram and main diagram.

The receiver is designed for reception of AM (A3, A3H), and SSB (A3A, A3J) signals and is a superheterodyne with an intermediate frequency of 600 kHz.

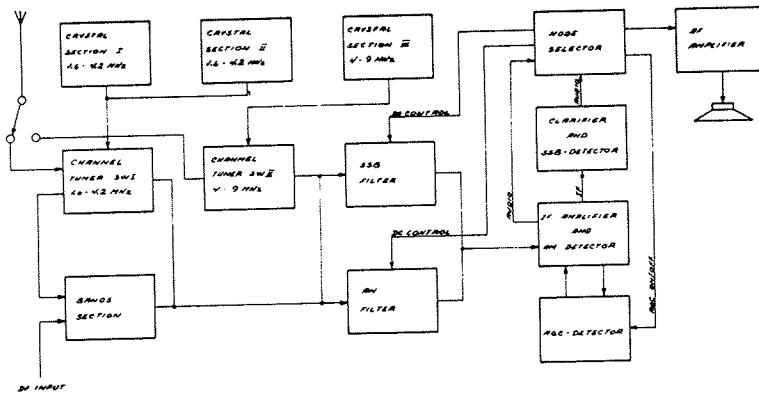

Analysis of the Block Diagram:

The signal from the aerial is fed to one of the two channel tuners (CHANNEL TUNER), which amplify and mix the aerial signal with crystal frequencies from the CRYSTAL SECTIONS, I, II and III, to an intermediate frequency of 600 kHz. The channel tuners are push-button controlled, and tuning of the selective circuits once made should need no further adjustment.

For reception of LW, NW, MW and SW with continuous tuning, the aerial is connected to the BANDS SECTION, which is a separate unit selecting the incoming signal and mixing it with the variable oscillator, resulting in the intermediate frequency.

The produced intermediate frequency signal is fed through either the AM FILTER or the SSB FILTER. Switching between these filters takes place electronically.

The signal is then passed on to the IF AMPLIFIER, which also contains the AM detector. The IF AMPLIFIER is a selective amplifier with a band-width wider than both the AM and SSB filter. There are three stages in the amplifier, two of which are AGC regulated.

The IF AMPLIFIER supplies a signal to the AGC DETECTOR, which contains an AGC amplifier, AGC detector and HANG AGC circuit.

The IF AMPLIFIER also supplies a signal to the CLARIFIER and SSB DETECTOR circuit.

The audio signal from AM and SSB detectors is fed to the AF AMPLIFIER via a volume control.

The above mentioned units are powered by a built-in POWER SUPPLY, which can be switched to 12 or 24 V DC. A 110/220 V AC version can be supplied on special order.

Channel Tuners

The two channel tuners are basically identical; only the value of the frequency-determining components differ. The following description is based on the SW I channel tuner.

The aerial tuned circuit is composed of a 3 section bandpass-filter with permeability tuning. The neonlamp GL 1001 and diodes D101 and D102 protect the transistor T101, which is the RF amplifier, against overload.

The mixer is a field effect transistor T102, which operates as a multiplicative mixer.

The oscillator signal to the mixer is taken from transistor T103, which operates as an emitter follower for the crystal oscillator T104. The transistor T105 is the amplitude stabilizing circuit, which shifts the operating point of the oscillator by rectification of the oscillator signal in its base until a constant amplitude is obtained.

The crystal oscillator is of the PIERCE-COLPITTS type.

Crystal Section

The selection of the individual crystals takes place mechanically. The 3 section band-pass-filter in the CHANNEL TUNER is tuned mechanically. The CRYSTAL SECTION has trimmer capacitors for alignment of the crystal frequencies.

Band Section

This unit incorporates a balanced mixer using two field effect transistors T301 and T302. T303 acts as impedance converter.

The diodes D301 and D302 together with the neonlamp GL1001 protect the mixer against overload.

The variable oscillator with transistor T305 is a grounded gate oscillator, which delivers its signal to the balanced mixer from the source T304 amplitude stabilizes the oscillator. When using the balanced mixer both the incoming aerial and the oscillator signals are suppressed at the output of the mixer.

AM Filter

This filter is a five-element tuned filter, which is loaded by a field effect transistor T401 acting as a buffer in order to avoid feedback from the IF amplifier when this is AGC regulated, due to input impedance variations.

The AM filter is switched in and out by shifting diodes D401 and D402.

SSB Filter

The SSB filter is a crystal filter with a carrier frequency of 600 kHz. The filter is terminated at the input with L501, C501 and C503.

At the output, the filter is terminated with L502, C504 and C505. The buffer stage T501 compensates for the insertion loss in the filter.

The SSB filter is switched in and out by additional shifting diodes D501 and D502.

IF AMPLIFIER

The IF AMPLIFIER is composed of three stages using transistors T703, T704 and T705. The first two stages are AGC regulated. These transistors are forward biased, which means that the gain is decreased by increasing current in the transistors. Transistors T701 and T702 are connected to operate as a DC AMPLIFIER. Their function is to supply T703 and T704 with AGC voltage, which is fed to the base of T701.

Transistor T706 operates as an AM detector. T706 peak-rectifies the incoming IF signal. The IF AMPLIFIER has a wide bandwidth, so that the final selectivity is determined by the AM and SSB filters in the front end of the receiver.

AGC SECTION

The signal from the IF AMPLIFIER is amplified by transistor T805. From a tap on the coil L801 this amplified signal is peak-rectified by diode D806. The reservoir capacitor C804 supplies voltage to the base of transistor T801, which operates as an AGC hold circuit.

The emitter circuit of T801 has two time constants. A short time constant comprising C802–R804 and a long one comprising C801–R800.

For SSB reception both time constants are switched into the circuit. The short time constant provides rapid reduction of the sensitivity of the receiver when a signal appears. C801, forming part of the long time constant, is charged to the peak value of the signal. When the base bias of T801 disappears, T801 cuts off, and the AGC voltage supplied to the IF AMPLIFIER via diodes D804 and D803 remains. This arrangement provides HANG AGC, which has the effect that the receiver will not operate on full sensitivity when the input signal disappears. This is the case during speech intervals during reception of DSB and SSB. The HANG AGC function will stop after abt. 3 sec. if the input signal disappears for more than abt. 3 sec. If the input signal drops more than abt. 10dB the sensitivity will also be adjusted after a few seconds.

The circuit controlling the HANG AGC is made up of transistors T802, T803 and T804. T802 and T803 are connected in such a way that if the base voltage at T802 is more than 0.7 V lower than the emitter voltage, then T802 and T803 will act as a short-circuit.

When a signal is supplied to the receiver, a voltage will be established on the AGC line as described. At the same time a higher voltage will be established at the base of T804 due to the peak-rectifying provided by diode D808, which is fed from the top of L801. C806 in the emitter circuit of T804 is charged to this higher voltage, by which T802 is blocked. When the incoming signal disappears, C806 is slowly discharged by the resistor P802 and thus the base voltage disappears from T802, whereas the AGC voltage across C801 will hang. When the base voltage of T802 drops 0.7 V below the emitter voltage owing to the discharge of C806, T802 and T803 will be momentarily conducting, and C801, C802 and C806 will rapidly be discharged through R809, and the receiver will have max. sensitivity.

In the AM position R804 is short-circuited to chassis and the connection to C802 is broken, so that only the long time-constant is switched in. T801 is constantly conducting and the HANG circuit is inoperative. This arrangement ensures that the voltage is independent of the modulation of the incoming signal.

The network with P801 and D802 is used for the adjustment of the operating point for the IF AMPLIFIER for max. amplification without signal on the aerial.

In position AGC-OFF the diodes D803 and D804 are connected to chassis so that they are cut off as a result of which the amplification is controlled only by P1002 (RF GAIN) via diode D801.

The RF GAIN control can be used with AGC applied, only the max. sensitivity of the receiver is reduced to a level, controlled by means of RF GAIN.

SSB DETECTOR – CLARIFIER

The SSB detector is equipped with a field effect transistor T605, which operates as multiplicative mixer between the IF signal and the variable 600 kHz oscillator signal containing the remaining circuits.

The variable 600 kHz signal is produced by mixing a 6.7 MHz and a 7.3 MHz crystal oscillator signal, the frequency of which is altered by means of a capacity diode.

The multiplicative mixing takes place by means of the transistors T603 and T604.

The crystal oscillator T601 and T602 are of the PIERCE-COLPITTS type. Both oscillators are provided with capacity diodes for optimum frequency stability.

AUDIO AMPLIFIER

The output transistors T903 operate in push-pull mode and drive the loudspeaker through the transformer T1001. The supply voltage to the output stage is 12 V. The driver transformer TR901 is driven by the transistor T902, which is driven by the amplifier T901.

From the output transformer a negative feed-back signal is applied to the emitter of the transistor T902.

An additional winding on the output transformer TR1001 is connected to the meter on the front panel in the NAVIGATION positions. This facility is used in direction finding operation. In the AM and SSB positions, the same meter tests the AGC voltage.

Remaining Circuits

The supply filter, fuses and plugs are mounted on a printed circuit board on the rear plate of the receiver, where are also located the socket connections for the transmitter and direction finder equipment.

12/24 V DC Power Unit

This power unit supplies 12 V and 18 V DC to the receiver. 18 V is used for all low level circuits and 12 V for the AF output stage.

The 12 V requirement is taken directly from the vessels batteries on 12 V operation, after the series regulator, with the power transistor T1101 and the zener diode D1102, on 24 V operation.

The diode D1101 protects against wrong polarity of the supply voltage.

The DC-DC converter composed of the transistors T1102 and T1103 and the transformer TR1101 delivers voltage to the rectifier circuit and the series regulator composed of the transistor T1104 and the zener diodes D1104 and D1105.

110/220 V AC Power Unit

This power unit supplies stabilized 12 V to the AF output stage of the receiver and stabilized 18 V to the low level circuitry.

The transformer TR1201 supplies rectified voltage to the two series regulators from the two secondary windings.

The 18 V series regulator is equipped with the transistor T1201 and zener diodes D1203 and D1204.

The 12 V series regulator is equipped with the power transistor T1204 operated by the emitter follower T1203, which again is driven by the transistor T1202. The zener diode D1205 forms the reference element for T1202. T1202 compares the reference voltage at the emitter with the base voltage, which is proportional to the output voltage, by means of the voltage divider composed of R1208 and R1209.

Conditions are stable, when the base voltage is about 0.7 V higher than the emitter voltage.

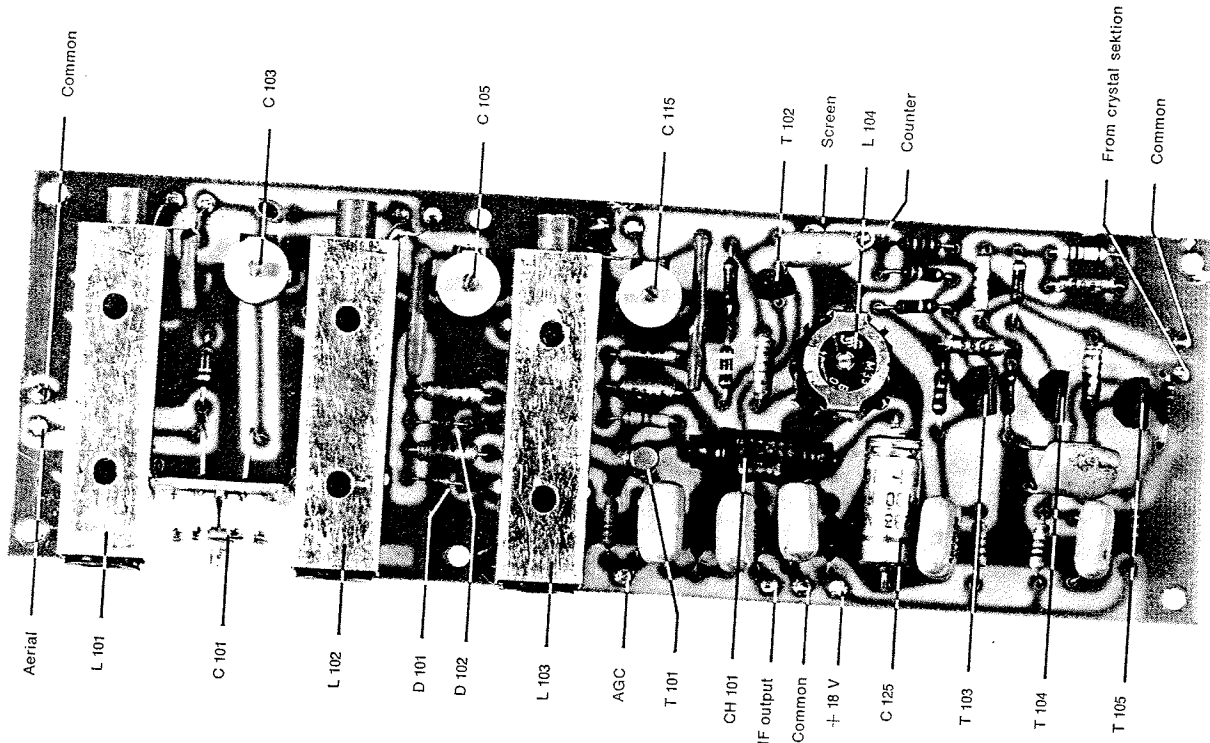

	T101	T103	T104	T105		T102
E	2,9	1,8	2,4	0,0	D	14,0
B	3,1	2,5	3,3	0,1	S	1,6
C	13,0	12,5	14,6	4,8	G	0,0

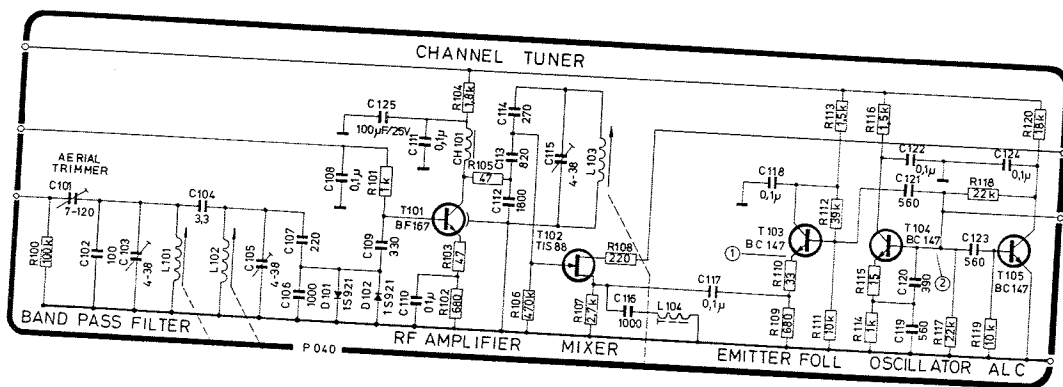

Channel tuner

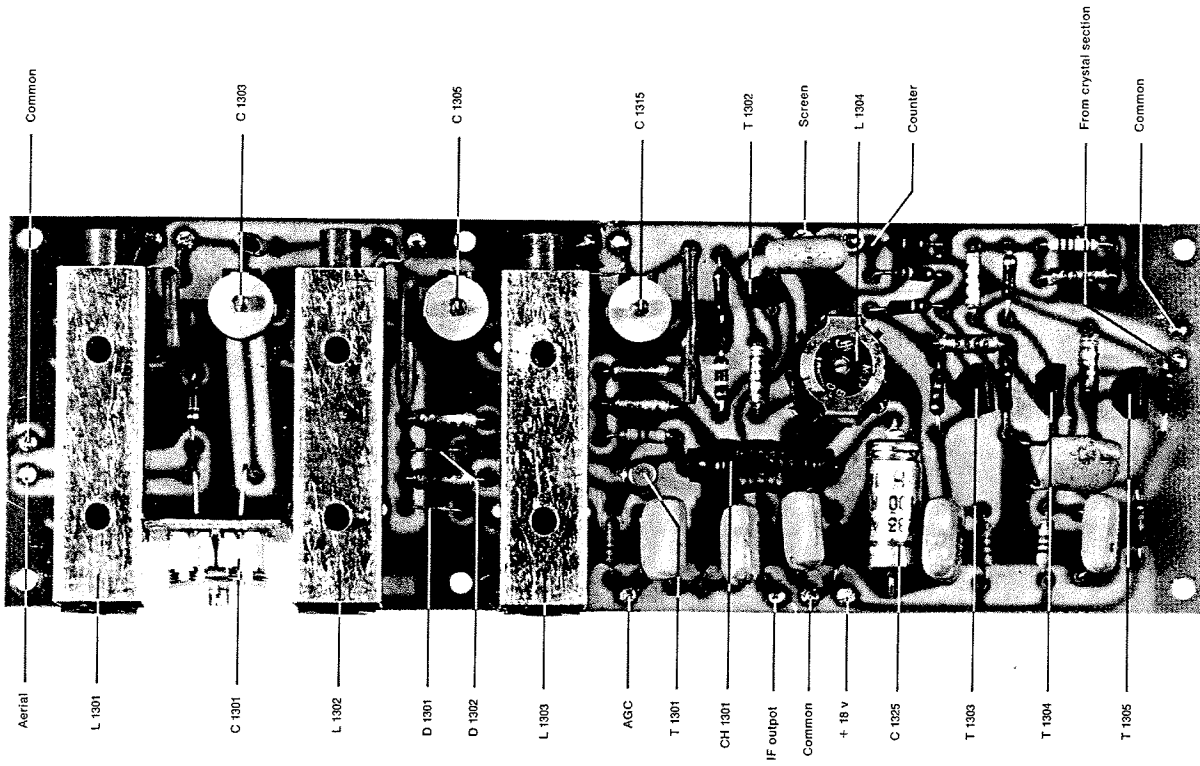

	T101	T103	T104	T105		T102
E	2,9	1,8	2,4	0,0	D	14,0
B	3,1	2,5	3,3	0,1	S	1,6
C	13,0	12,5	14,6	4,8	G	0,0

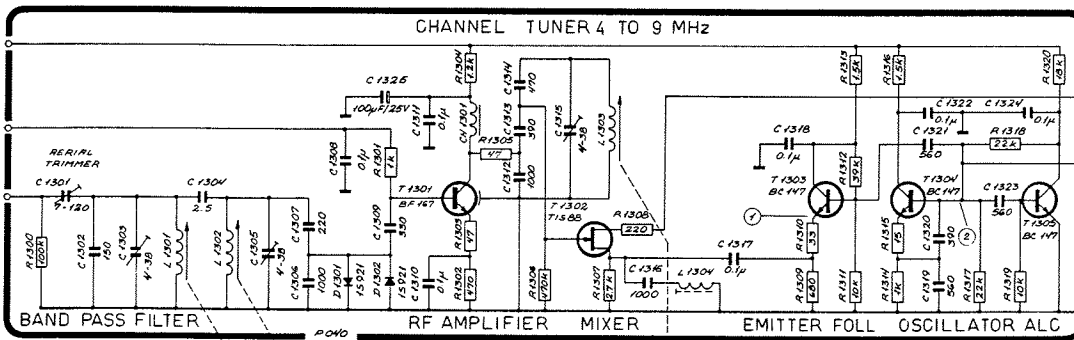

Channel tuner SW II

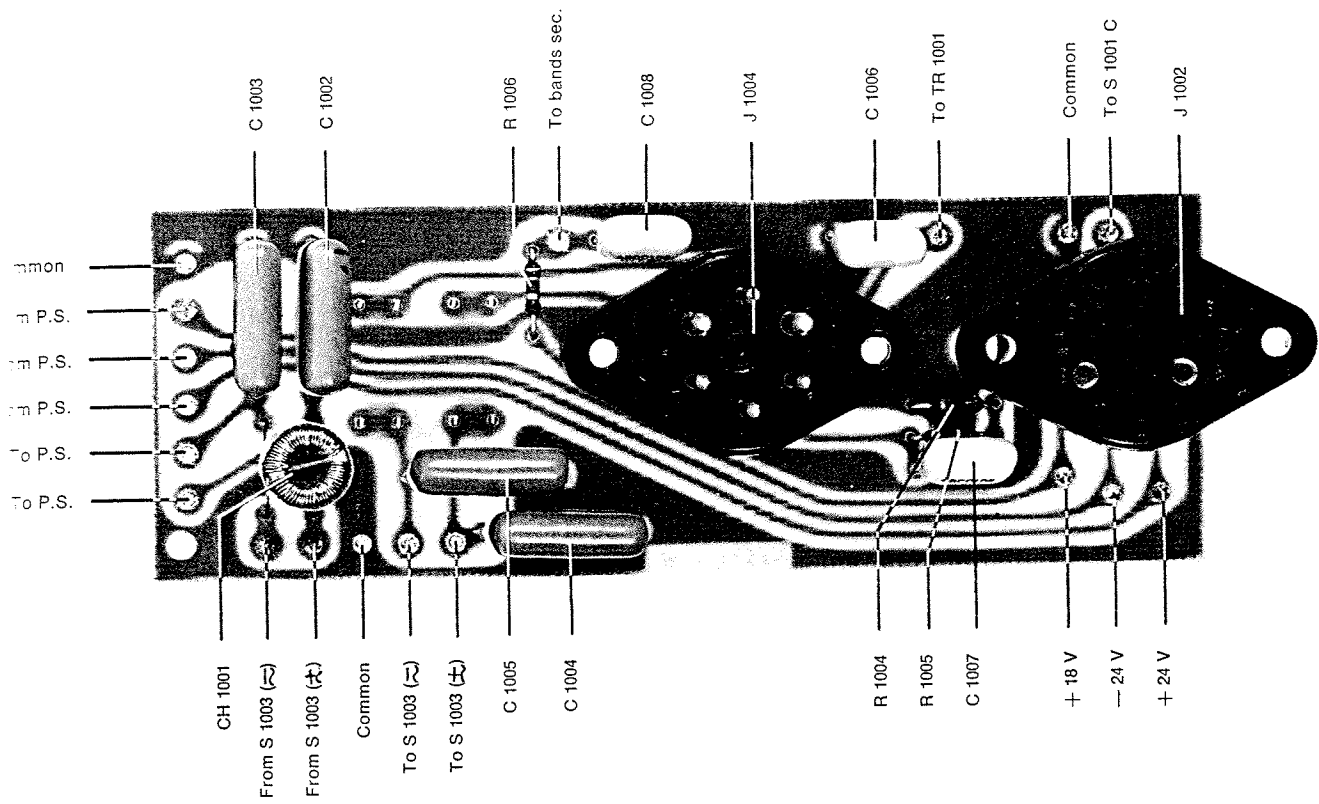

Filter section

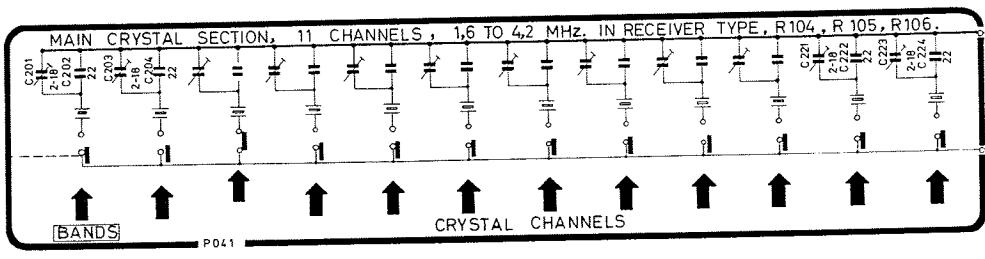
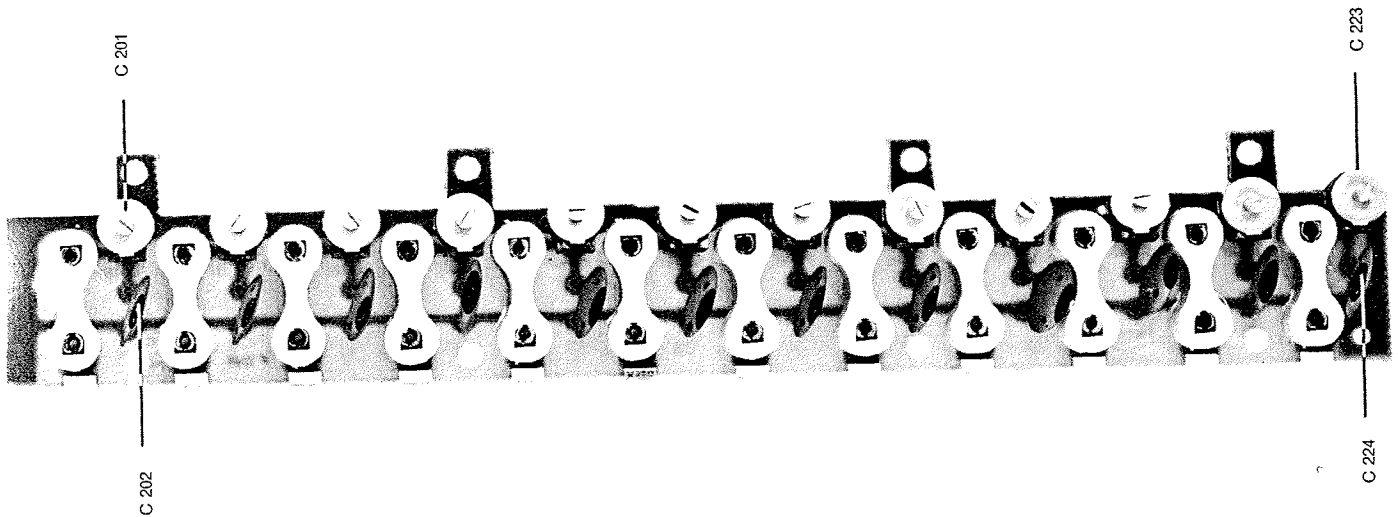

Crystal section

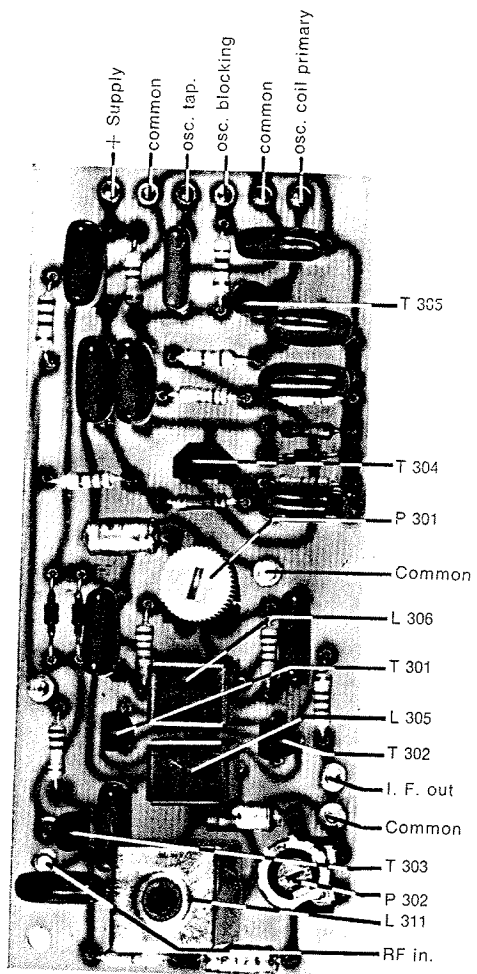
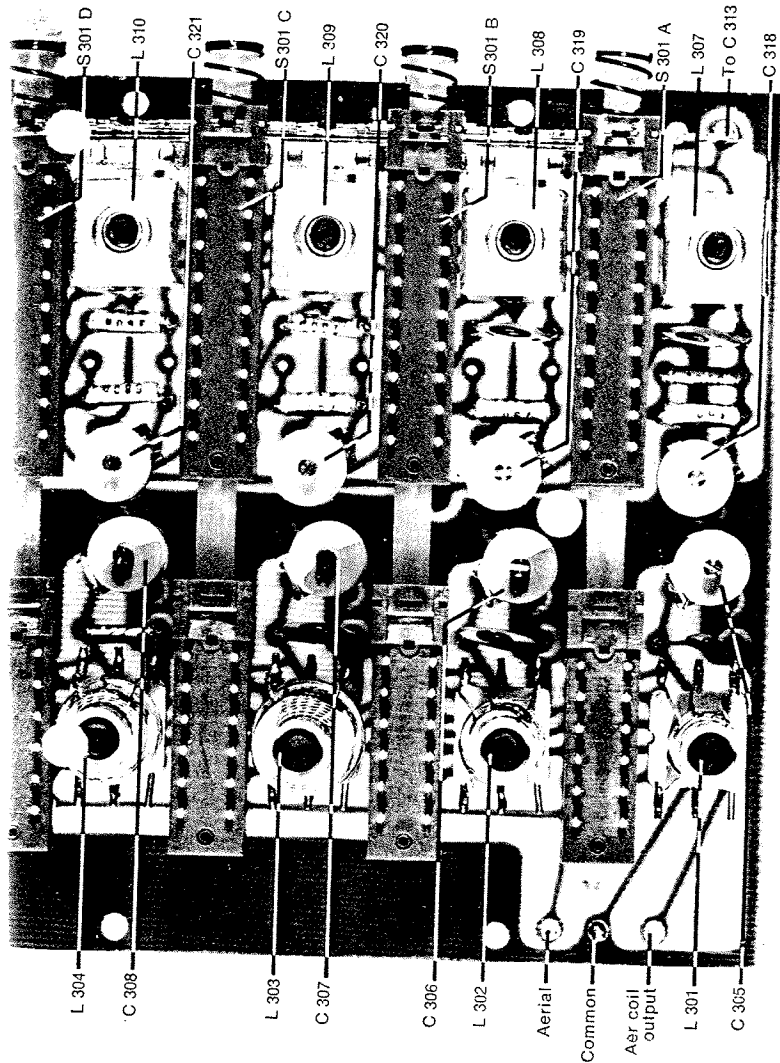

	T 301	T 302	T 303	T 305		T 304
S	3,0	3,0	2,5	5,8	E	2,3
G	0	0	0	3,8	B	1,2
D	14,1	14,1	17,1	17,0	C	3,8

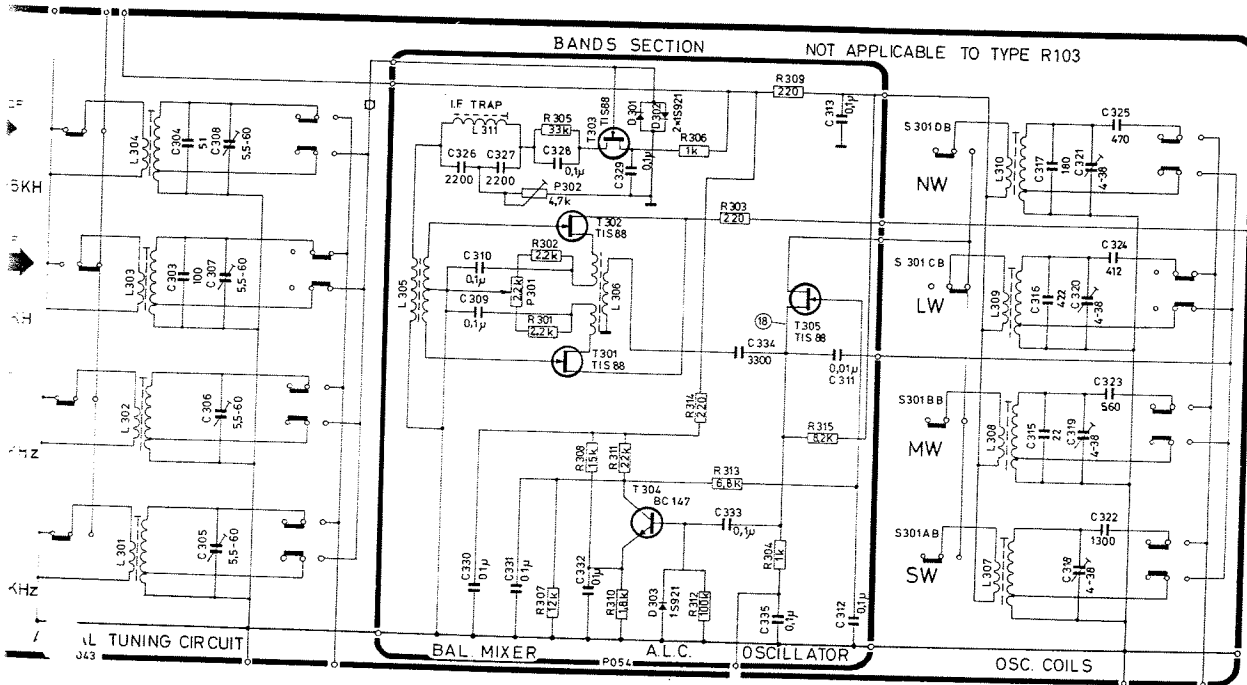

Bands section

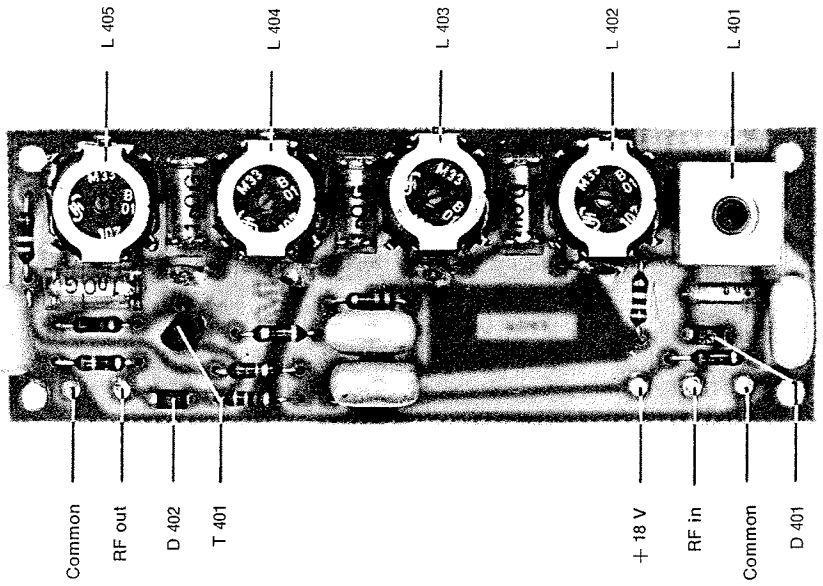

	T 401
D	14,2
S	7,6
G	5,8

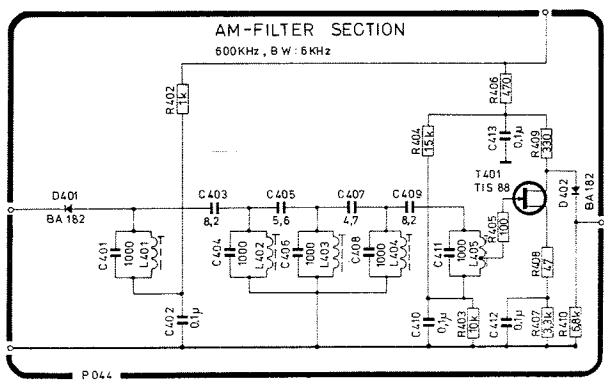

AM - filter section

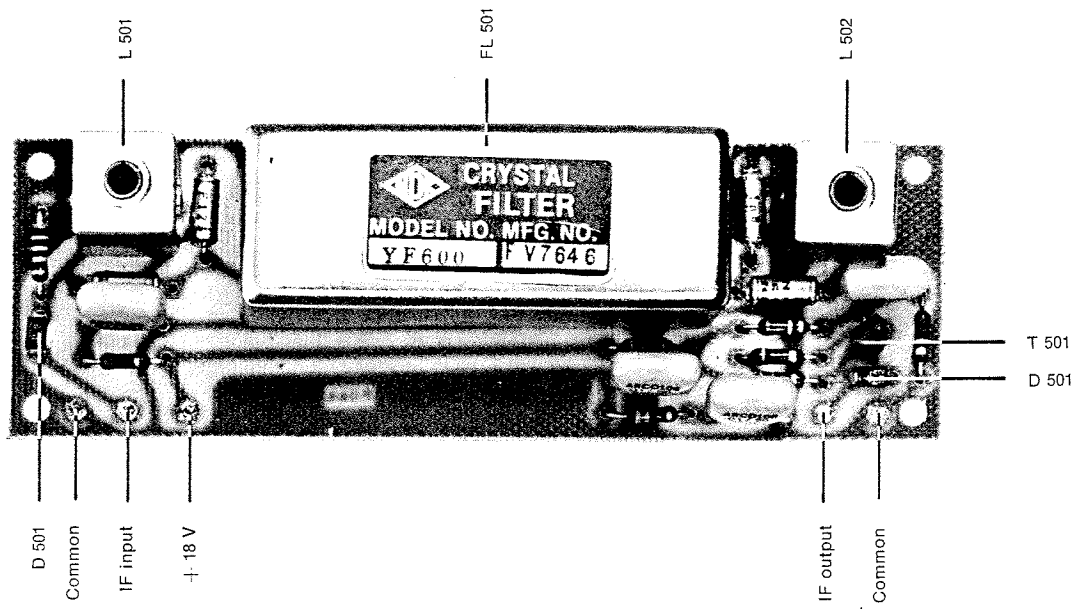

	T 501
D	14,1
S	6,9
G	5,0

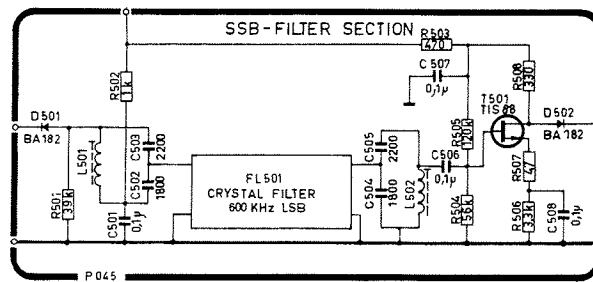

SSB-filter section

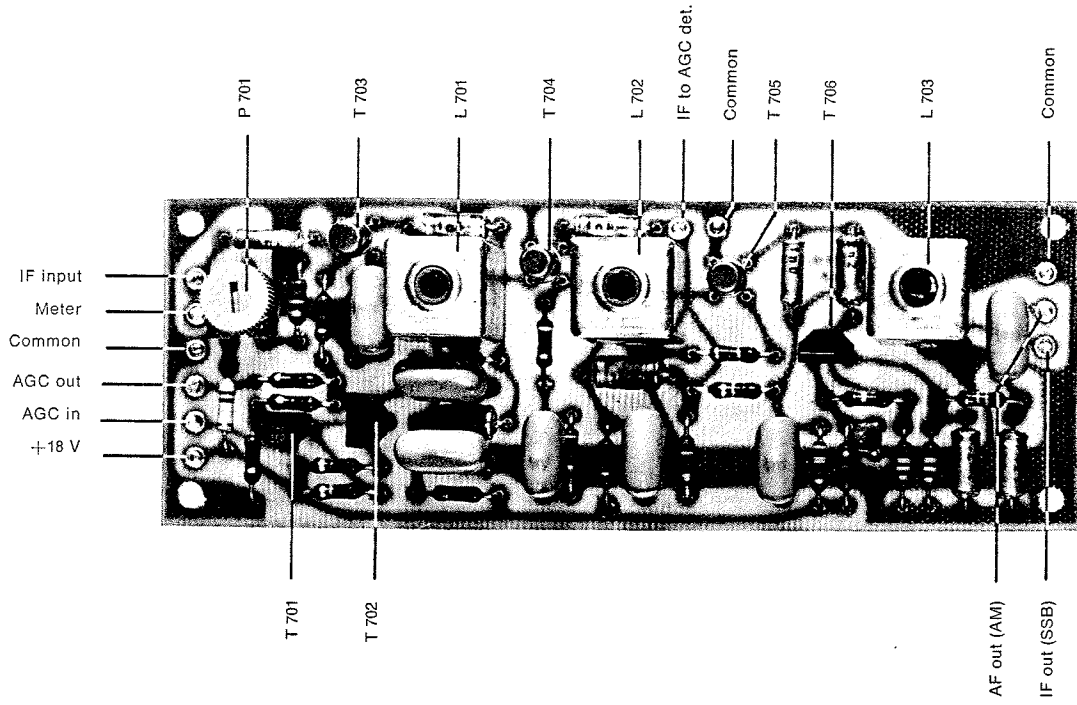

	T701	T702	T703	T704	T705	T706
E	1,4	2,6	1,9	1,9	5,0	4,7
B	2,0	16,9	2,6	2,6	5,8	5,2
C	16,9	17,6	12,9	13,3	16,5	17,4

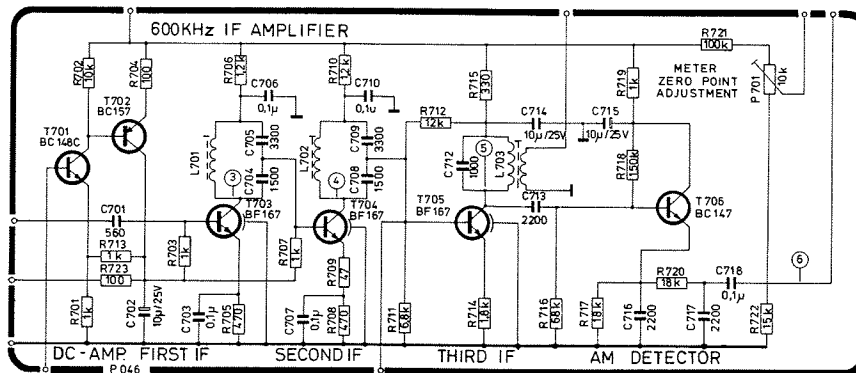

600 KHz IF amplifier

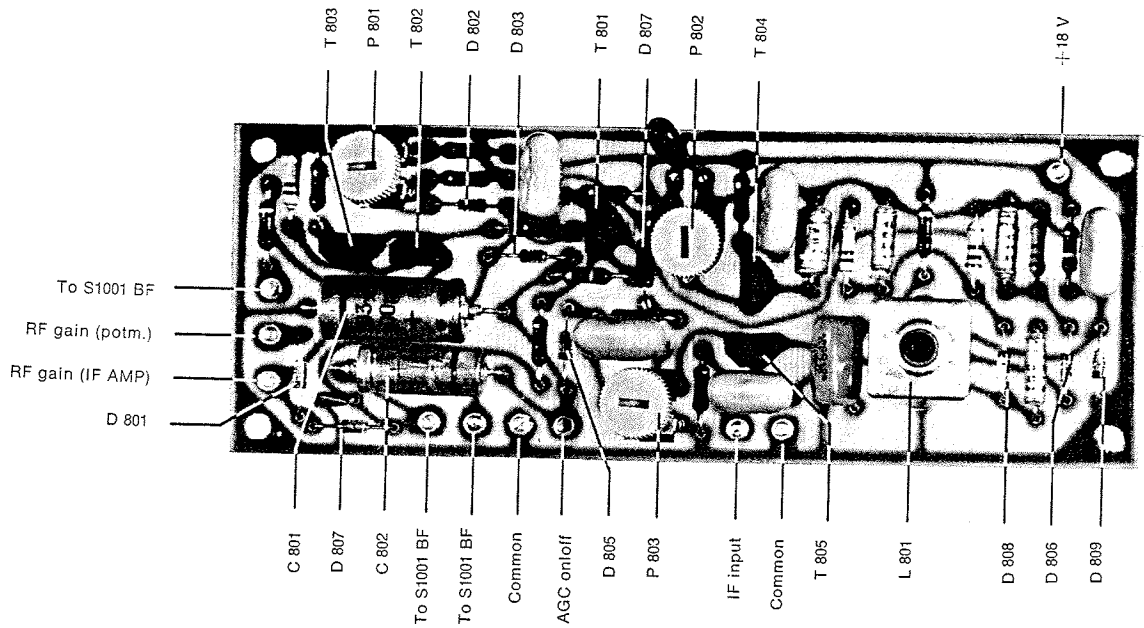

	T 801	T 802	T 803	T 804	T 805
E	0,7	1,0	0,0	0,8	2,3
B	0,5	0,5	0,2	0,7	2,9
C	17,8	0,2	0,5	17,8	16,4

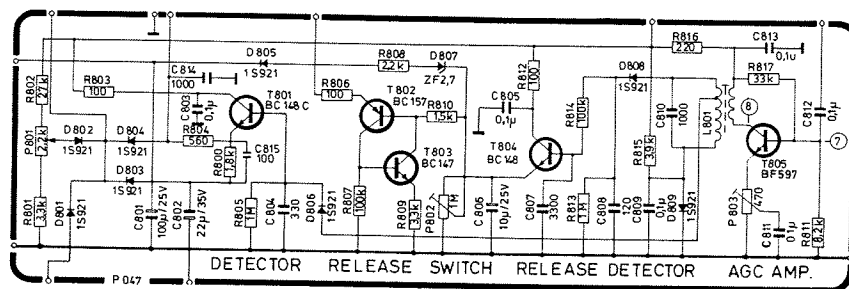

AGC detector

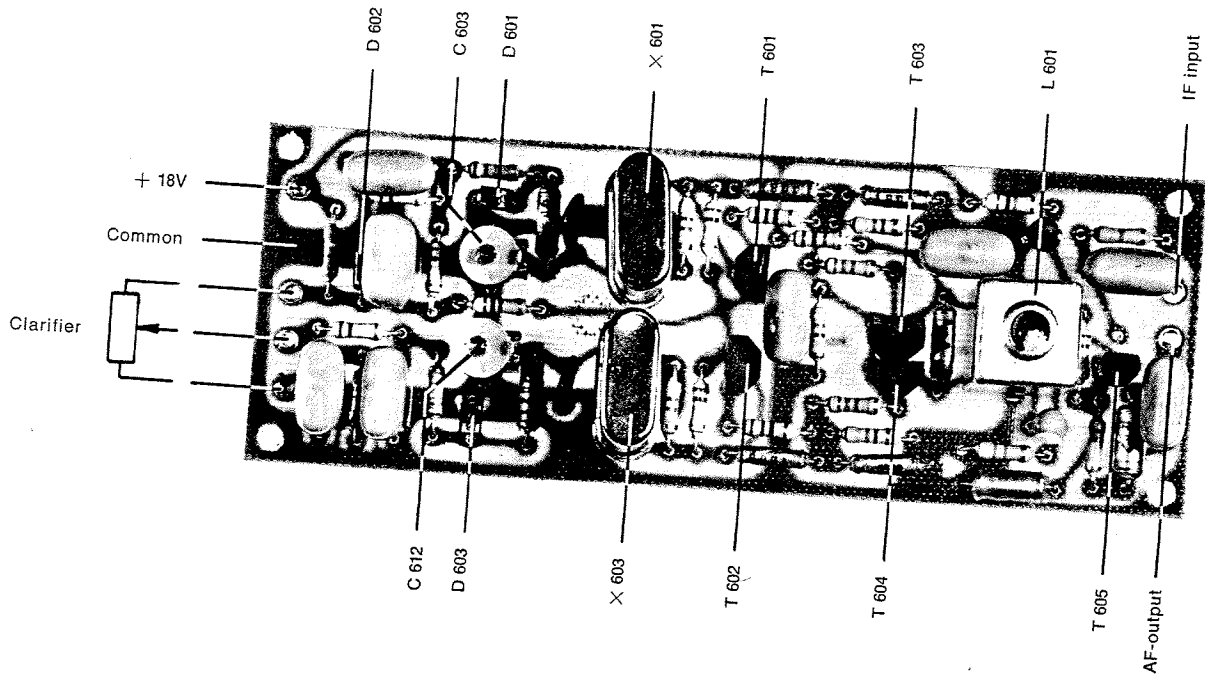

	T601	T602	T603	T604		T605
E	3,2	2,9	3,3	3,2	D	12,0
B	2,4	2,4	3,2	2,9	S	3,1
C	7,8	7,8	8,2	8,2	G	0,0

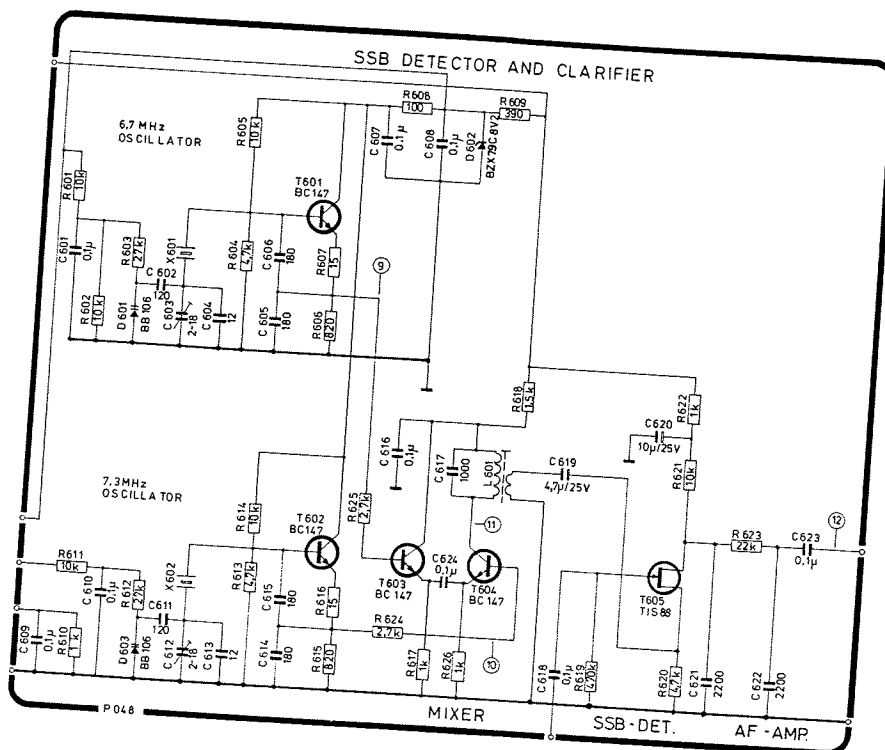

SSB detektor and clarifier

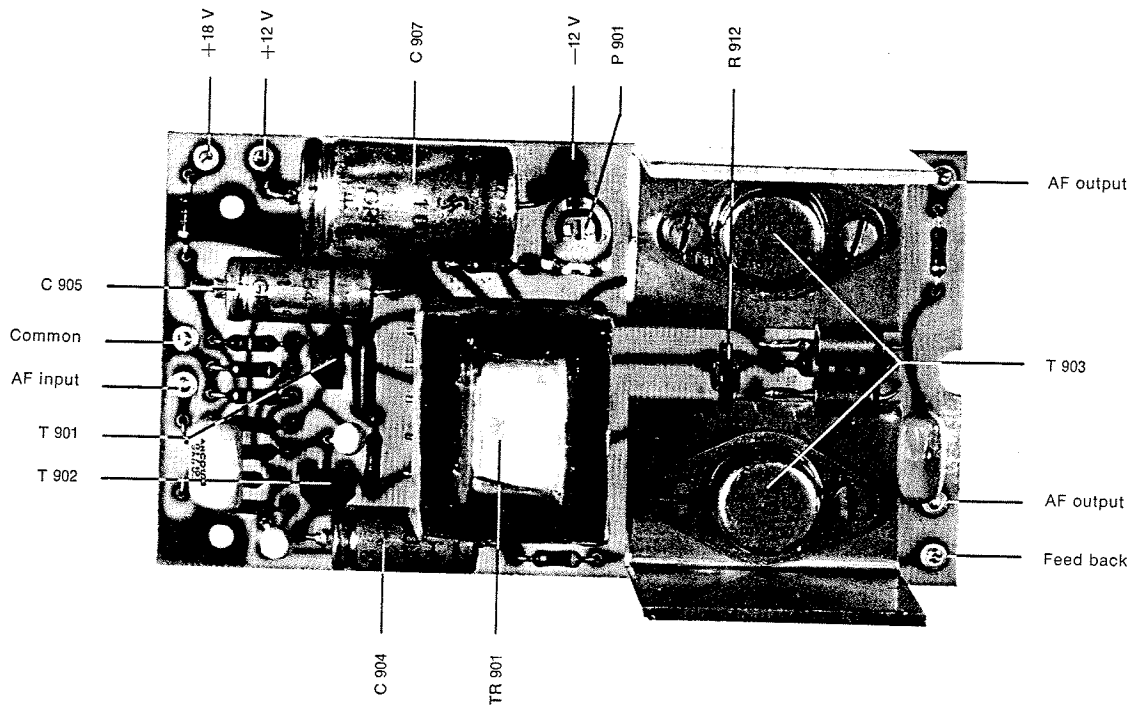

	T901	T902	T903	T904
E	0,4	4,3	-14 m	-14 m
B	1,0	4,9	-14 2 m	-142 m
C	.9,7	15,1	-12,2	-12,2

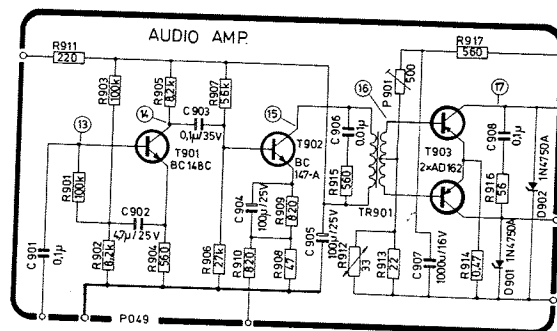

Audio amplifier

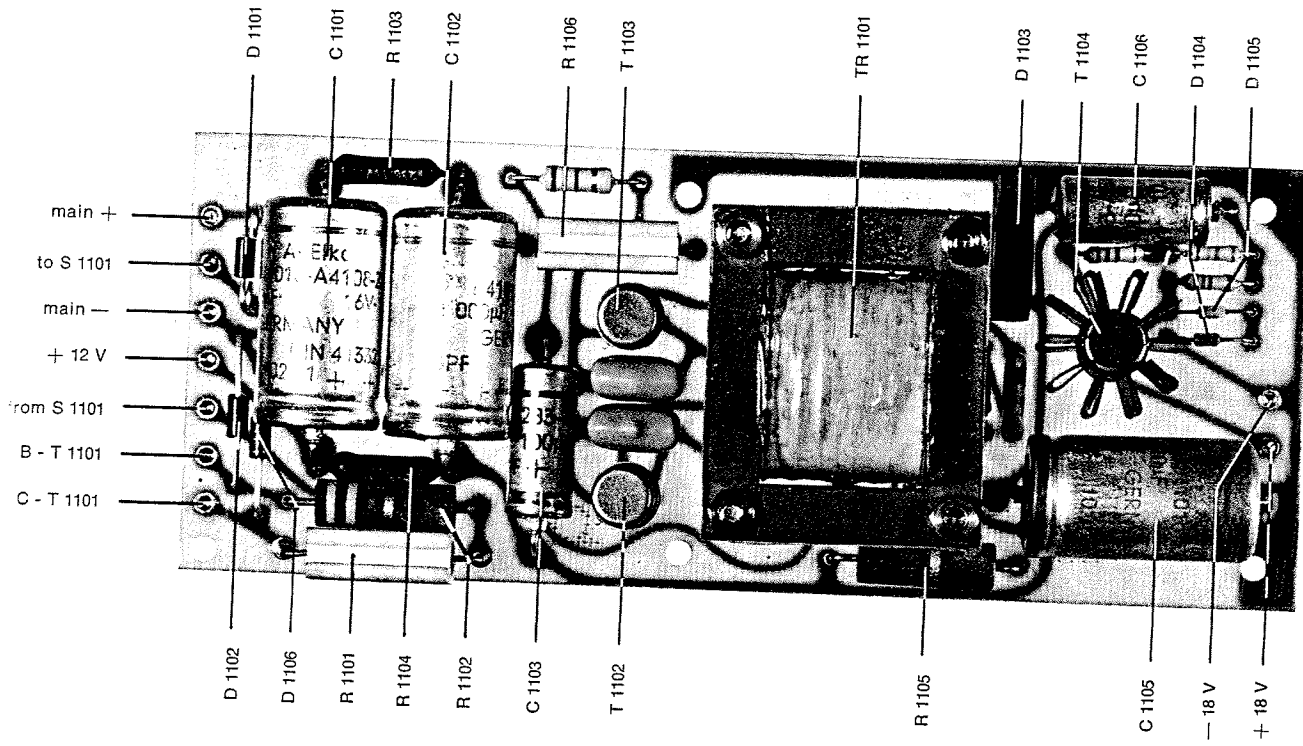

	T 1101	T 1102	T 1103	T 1104
E	12,3	1,1	1,1	18,0
B	13,0	-0,5	-0,5	18,7
C	22,4	11,0	11,0	25,6

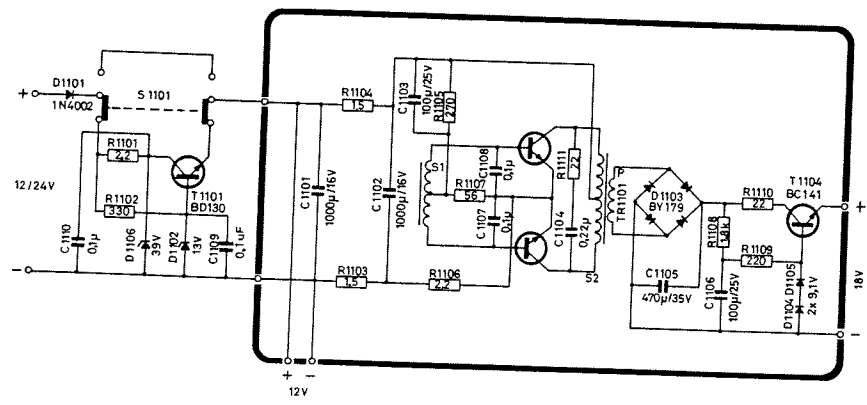

12/24 V DC power supply

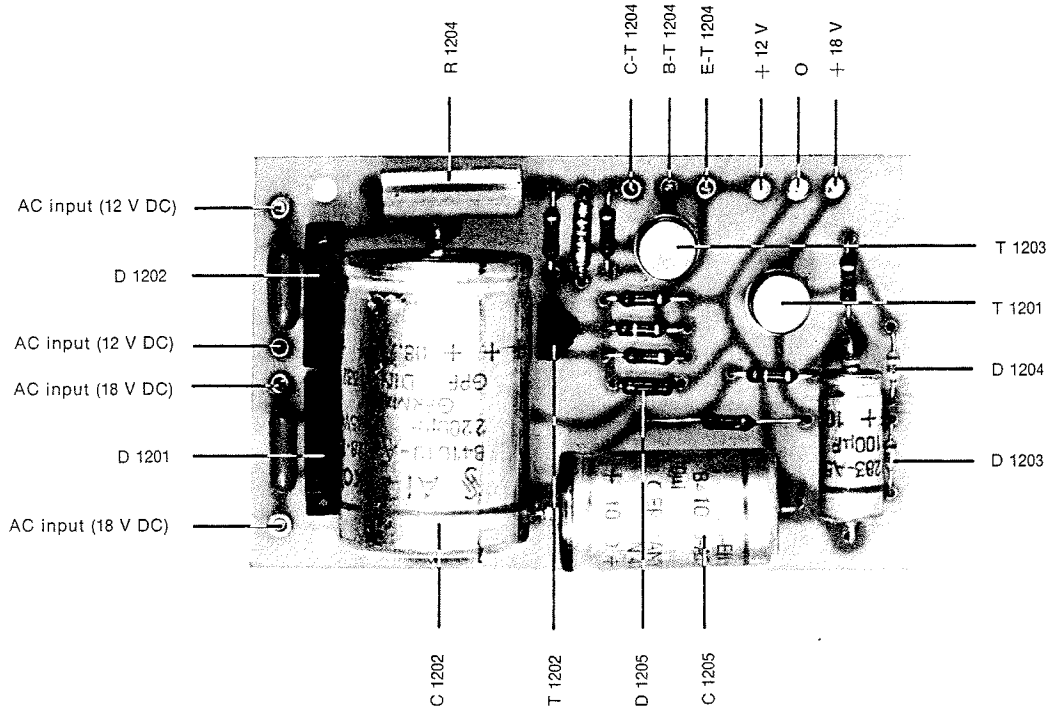

	T 1201	T 1202	T 1203	T 1204
E	17,6	5,6	14,6	13,9
B	18,2	6,2	15,0	14,6
C	27,0	15,0	27,8	26,8

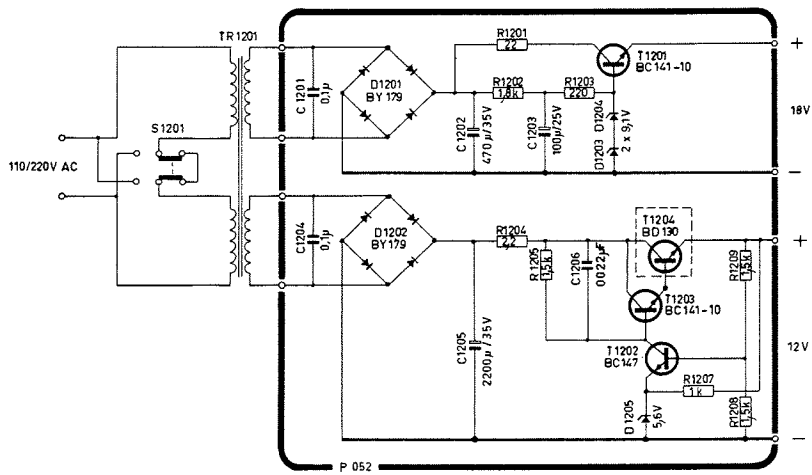

110/220 V AC power supply

Measurement point	Voltage <i>V_{pp}</i>	Xtal. control in operation		V.F.O. in operation (Mode either AM or SSB)	A.F.
		Position of mode switch			
		A.M.	S.S.B.		
1	1,2	●	●		
2	1,7	●	●		
3	0,02		●		
4	0,4		●		
5	1,0		●		
6	0,2	●			
7	0,13		●		
8	9,1		●		
9	1,2		●		
10	1,0		●		
11	13,5		●		
12	0,5		●		
13	0,05				●
14	0,44				●
15	6,5				●
16	1,1				●
17	10,6				●
18	0,29			●	

Typical A.C. Voltages at Points on Main Diagram shown circled

Tensions alternatives types, repérées sur le schéma général par les nombres entourés d'un cercle.

Condition de test:

Entrée antenne: 1 mV eff.

Circuit antenne: 250 pF en série avec 10 ohms ou 50 ohms seul.

Modulation du générateur de test: M.A.: 30 % 1kHz. BLU.: Rien.

Les tensions A.F. sont mesurées pour une puissance de sortie de 0,5 W avec L'AGC en service.

Typically A.C. voltages indicated by circled numbers in main diagram.

Test conditions:

Antenna input: 1 mV RMS.

Dummy antenna: 250 pF in series with 10 ohm or 50 ohm alone.

Modulation of testgenerator: AM: 30 % 1kHz SSB: none

AF voltages measured for 0,5 W output with AGC-ON.

All voltages measured as peak to peak voltages with an oscilloscope. (Input impedance more than 1MΩ in parallel with max. 20pF).

Typiske vekselspændinger angivet ved indcirklede numre i hoveddiagrammet.

Målebetiingelser:

Antenne input: 1 mV RMS.

Kunst antenne: 250 pF i serie med 10 ohm eller 50Ω rent ohmsk.

Modulation af målesender: AM: 30 % 1kHz. SSB: Ingen.

LF spændinger målt for 0,5 W output med AGC-ON.

Alle spændinger målt som spids-spids spændinger med oscilloscop. (Indgangsmodstand større end 1MΩ parallelt med max. 20 pF).

**Typical A. C. Voltage chart
for SAILOR R110**

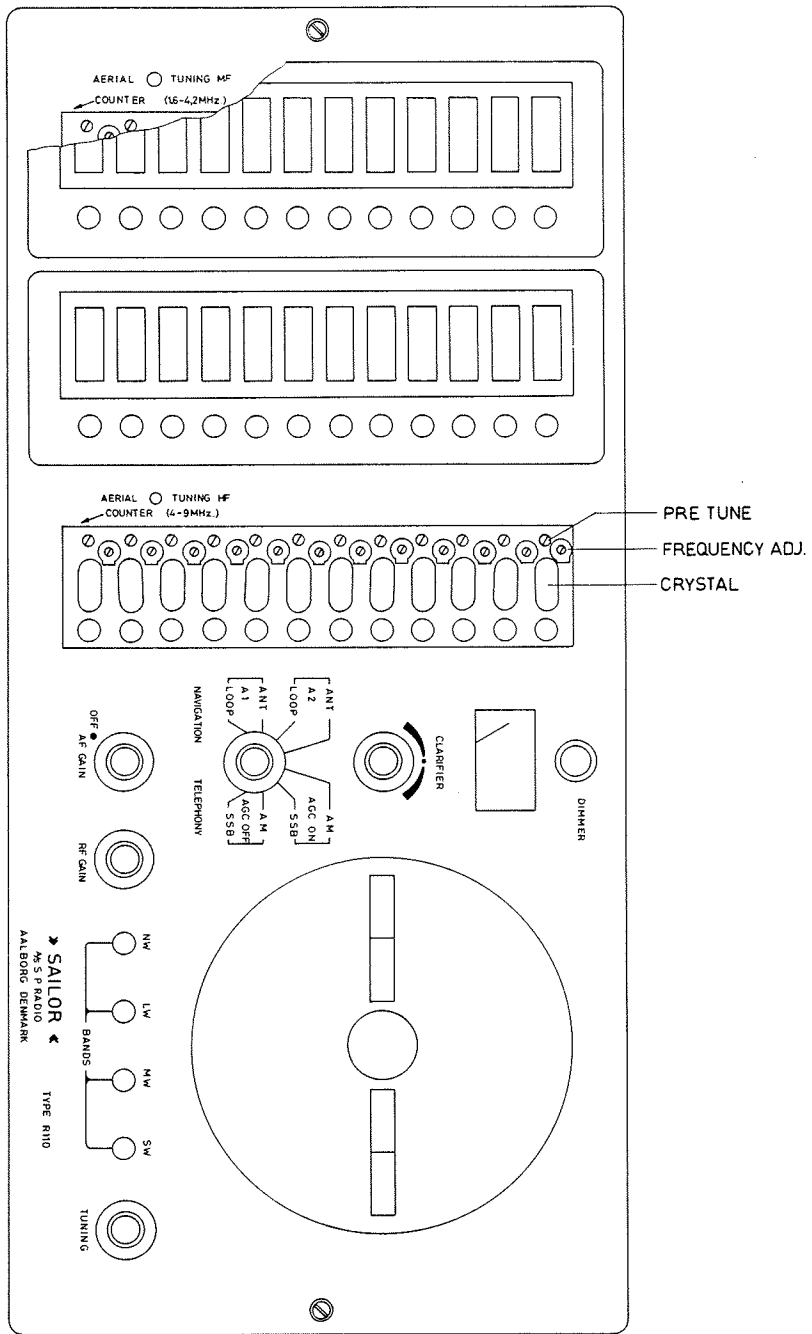

R 110. Front view

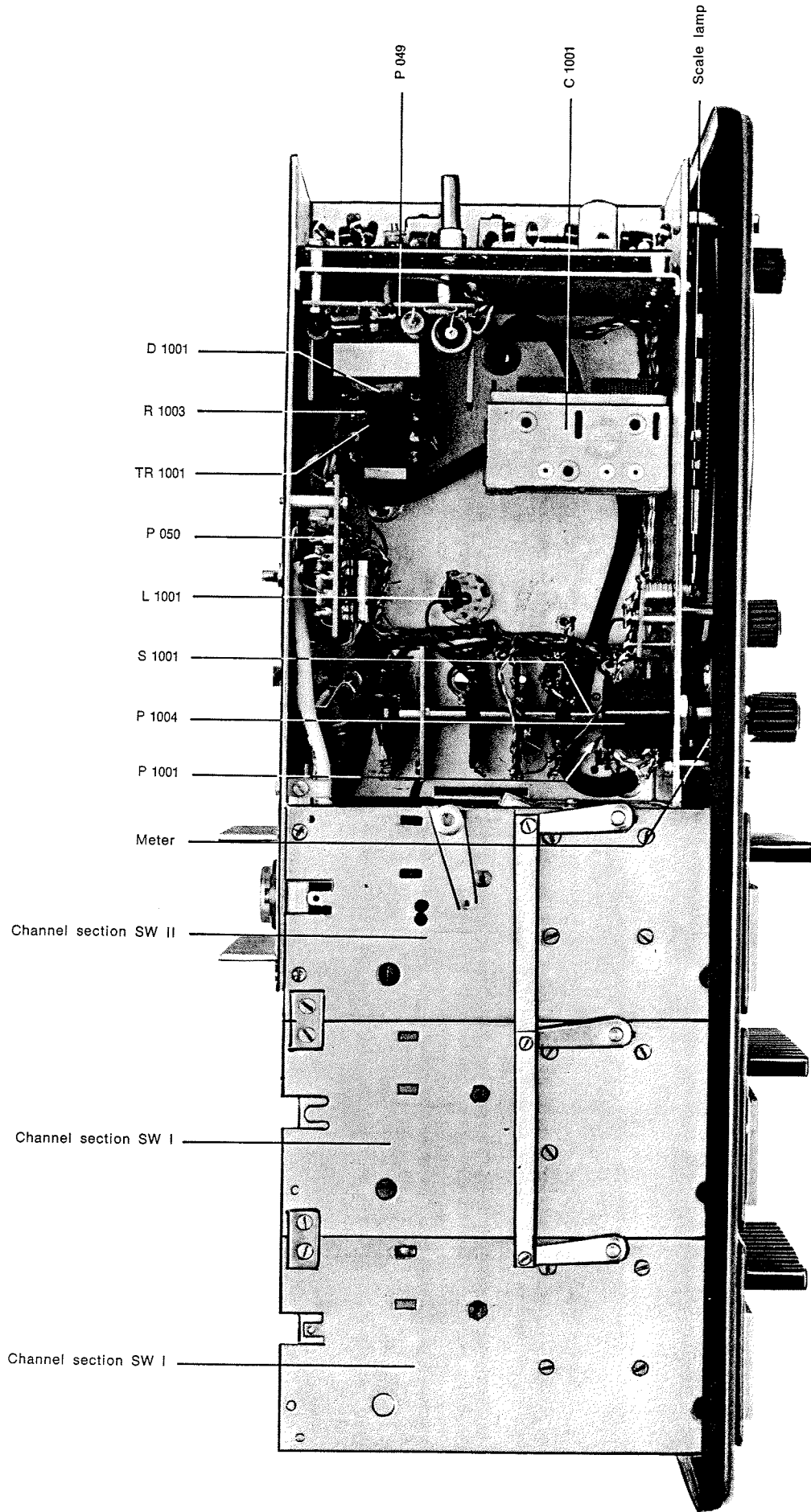

R110. Top view

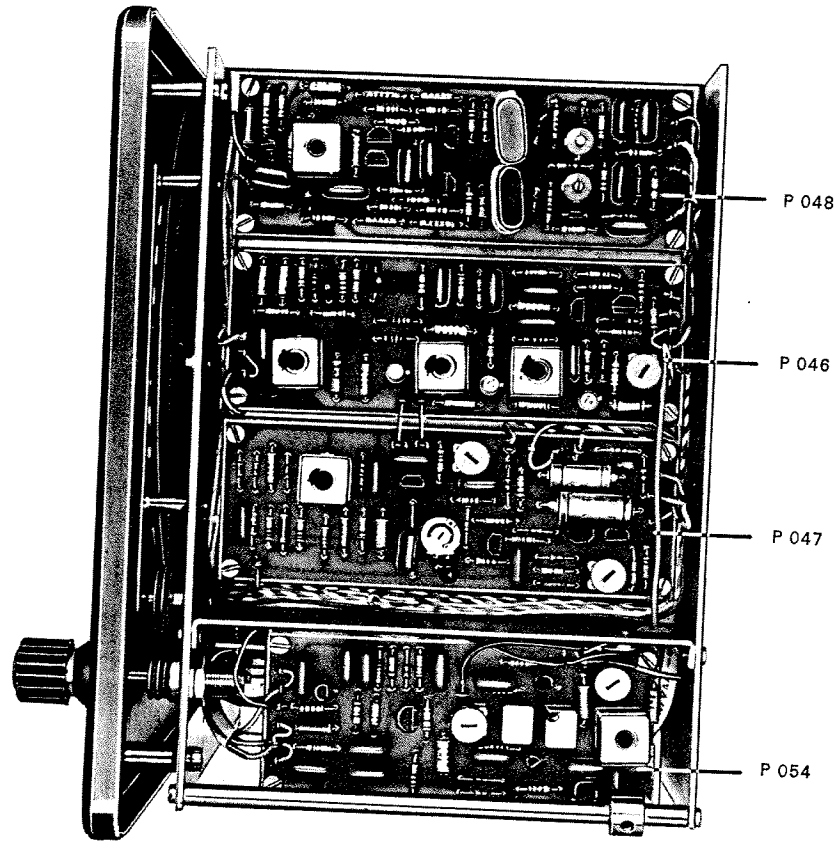

R110. Right side view

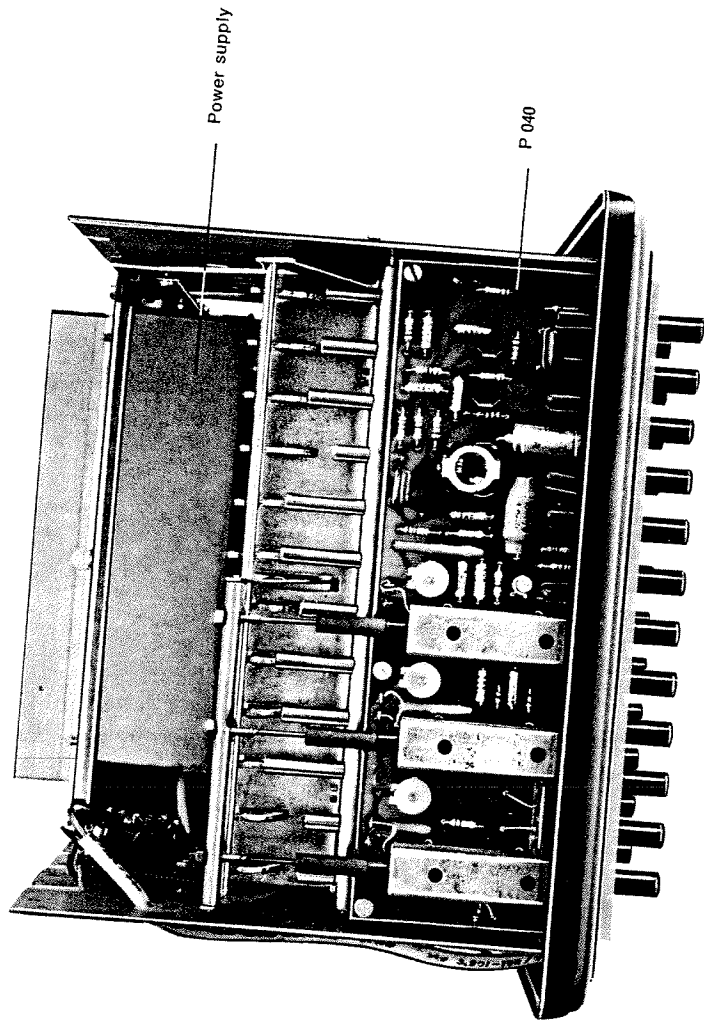

R110. Left side view

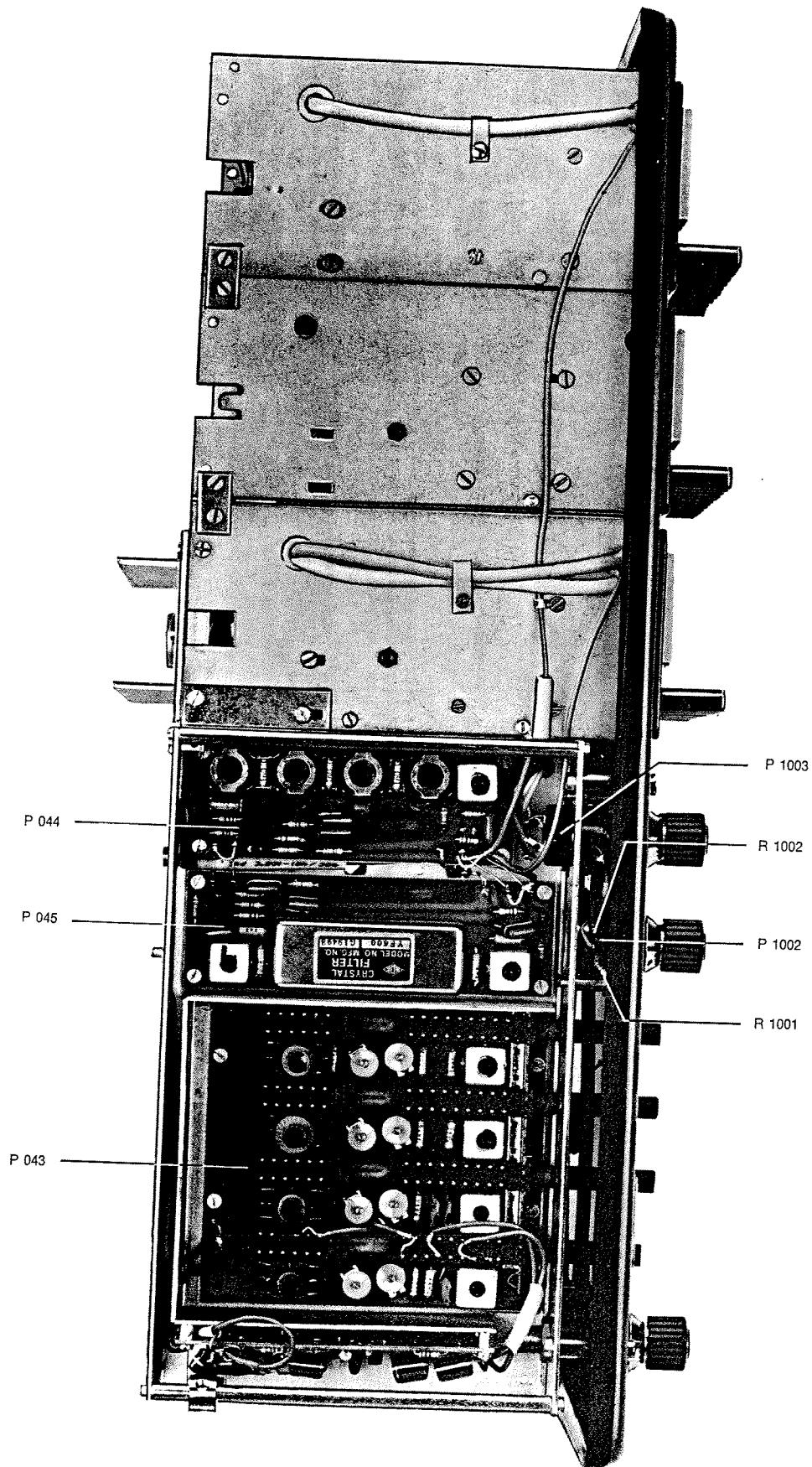

R 110. Bottom view

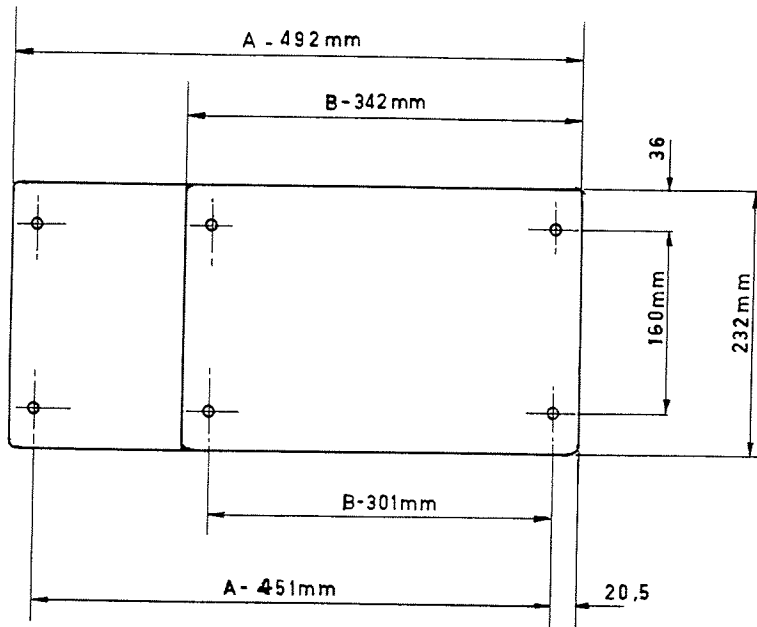

Dimns. prefixed 'A' refer to R105, R106 & R110 only
 Dimns. prefixed 'B' refer to R103 & R104

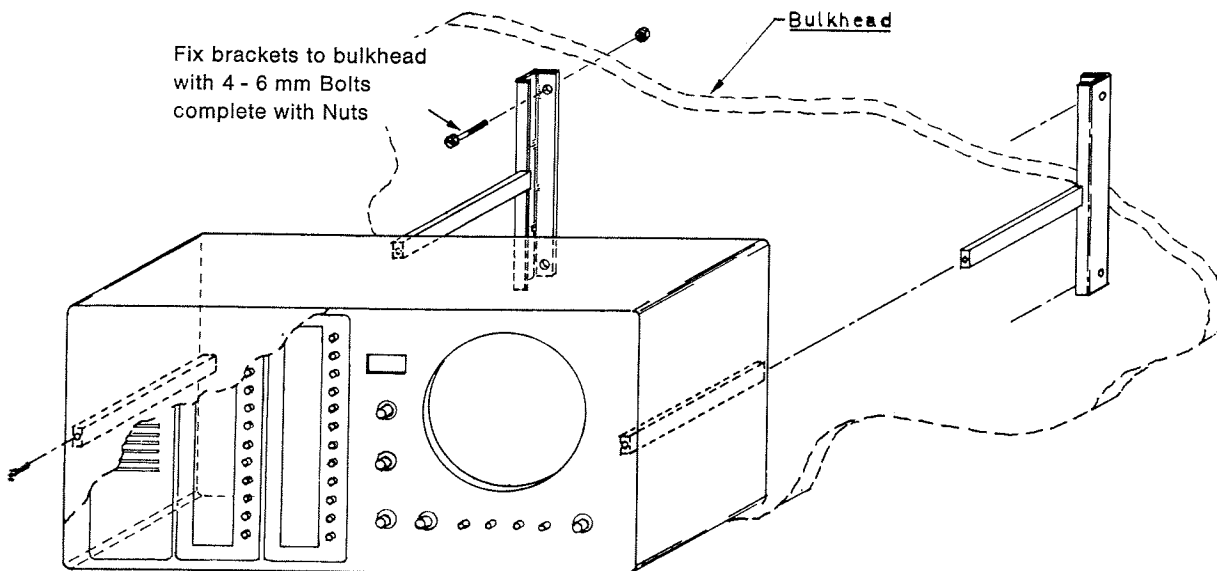

After sliding receiver into position on brackets
 Secure with screws provided.

**Mounting R103, R104, R105, R106
 or R110 to bulkhead**

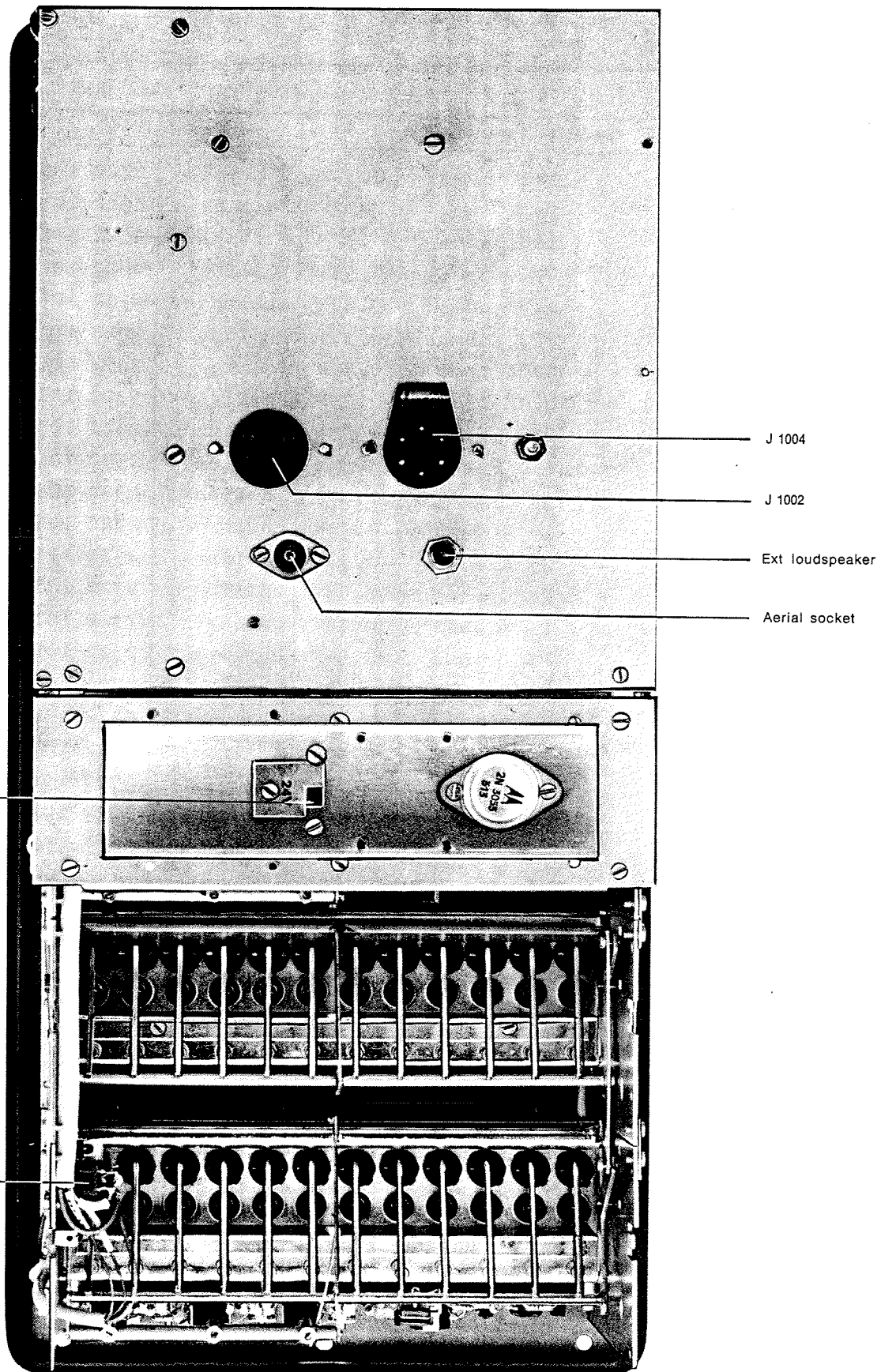

R110. Rear view

□ CHANNEL TUNER SW I 1.6 - 4.2 MHz R103 R104 R105 R106 R110 R114 R115

Symbol	Description	Manufact.	
R 100 ^x	Resistor	100K ohms	0.33W Philips 2322 101 33104
R 101	Resistor	1 K ohm	0.33W Philips 2322 101 33102
R 102	Resistor	680 ohms	0.33W Philips 2322 101 33681
R 103	Resistor	47 ohms	0.33W Philips 2322 101 33479
R 104	Resistor	1.8K ohms	0.33W Philips 2322 101 33182
R 105	Resistor	47 ohms	0.33W Philips 2322 101 33479
R 106	Resistor	470K ohms	0.33W Philips 2322 101 33474
R 107	Resistor	2.7K ohms	0.33W Philips 2322 101 33272
R 108	Resistor	220 ohms	0.33W Philips 2322 101 33221
R 109	Resistor	680 ohms	0.33W Philips 2322 101 33681
R 110	Resistor	33 ohms	0.33W Philips 2322 101 33339
R 111	Resistor	10 K ohms	0.33W Philips 2322 101 33103
R 112	Resistor	39 K ohms	0.33W Philips 2322 101 33393
R 113	Resistor	1.5K ohms	0.33W Philips 2322 101 33152
R 114	Resistor	1 K ohm	0.33W Philips 2322 101 33102
R 115	Resistor	15 ohms	0.33W Philips 2322 101 33159
R 116	Resistor	1.5K ohms	0.33W Philips 2322 101 33152
R 117	Resistor	22 K ohms	0.33W Philips 2322 101 33223
R 118	Resistor	22 K ohms	0.33W Philips 2322 101 33223
R 119	Resistor	10 K ohms	0.33W Philips 2322 101 33103
R 120	Resistor	18 K ohms	0.33W Philips 2322 101 33183
T 101	Transistor		Siemens BF 167
T 102	Transistor		Texas TIS 88A
T 103	Transistor		Siemens BC 147A
T 104	Transistor		Siemens BC 147A
T 105	Transistor		Siemens BC 147A
	x Not used in R114		

a CHANNEL TUNER SW I 1.6 - 4.2 MHz R103 R104 R105 R106 R110 R114 R115

Symbol	Description	Manufact.	
C 101 ^x	Capacitor trimmer 7-120pF teflon	Dau	116.3901.120
C 102	Capacitor ceramic 100 pF \pm 5% 250V	Ferroperm	9/0121.3 insul.
C 103	Capacitor trimmer 4-38 pF teflon	Dau	109.3901.038
C 104	Capacitor ceramic 3.3 pF \pm 0.25pF	Ferroperm	9/0112.9 400V
C 105	Capacitor trimmer 4-38 pF teflon	Dau	109.3901.038
C 106	Capacitor polystyrene 1000 pF \pm 2% 125V	Philips	2222 425 31002
C 107	Capacitor ceramic 220 pF \pm 5% 250V	Ferroperm	9/0121.3 insul.
C 108	Capacitor polyester 0.1 uF \pm 10% 250V	Efco	PMT
C 109	Capacitor polystyrene 330 pF \pm 2% 250V	Philips	2222 426 33301
C 110	Capacitor polyester 0.1 uF 250V	Efco	PMT
C 111	Capacitor polyester 0.1 uF 250V	Efco	PMT
C 112	Capacitor polystyrene 1800 pF \pm 2% 125V	Philips	2222 425 31802
C 113	Capacitor polystyrene 820 pF \pm 2% 125V	Philips	2222 425 38201
C 114	Capacitor ceramic 270 pF \pm 5% 250V	Ferroperm	9/0121.3 insul.
C 115	Capacitor trimmer 4-38 pF teflon	Dau	109.3901.038
C 116	Capacitor polyester 1000 pF \pm 2% 125V	Philips	2222 425 31002
C 117	Capacitor polyester 0.1 uF 250V	Efco	PMT
C 118	Capacitor polyester 0.1 uF 250V	Efco	PMT
C 119	Capacitor polystyrene 560 pF \pm 2% 125V	Philips	2222 425 35601
C 120	Capacitor polystyrene 390 pF \pm 2% 250V	Philips	2222 426 33901
C 121	Capacitor polystyrene 560 pF \pm 2% 125V	Philips	2222 425 35601
C 122	Capacitor polyester 0.1 uF 250V	Efco	PMT
C 123	Capacitor polystyrene 560 pF \pm 2% 125V	Philips	2222 425 35601
C 124	Capacitor polyester 0.1 uF 250V	Efco	PMT
C 125	Capacitor electrolytic 100 uF 25V	Siemens	B41283-A5107-Z
^x	Not used in R114		
Ch101	Choke coil 1 mH \pm 10%	Prahn	1580/9K
D 101	Diode	Texas/Sie.	1S921/1N4148
D 102	Diode	Texas/Sie.	1S921/1N4148
L 101	Aerial coil 1	S.P.	Drg.no. TL 002
L 102	Aerial coil 11	S.P.	Drg.no. TL 002
L 103	RF coil	S.P.	Drg.no. TL 002
L 104	Shunt coil 600 kHz	S.P.	Drg.no. TL 003

a

BANDS SECTION R104 R105 R106 R110 C301

Symbol	Description	Manufact.	
C 301	Not used		
C 302	Not used		
C 303	Capacitor polystyrene 100 pF \pm 2% 500V	Philips	2222 427 31001
C 304	Capacitor polystyrene 51 pF \pm 2% 500V	Philips	2222 427 35109
C 305	Capacitor trimmer 5.5 - 60 pF	Dau-Tefl.	109.4901.060
C 306	Capacitor trimmer 5.5 - 60 pF	Dau-Tefl.	109.4901.060
C 307	Capacitor trimmer 5.5 - 60 pF	Dau-Tefl.	109.4901.060
C 308	Capacitor trimmer 5.5 - 60 pF	Dau-Tefl.	109.4901.060
C 309	Capacitor polyester 0.1 uF 250V	Efco	PMT (new type)
C 310	Capacitor polyester 0.1 uF 250V	Efco	PMT (new type)
C 311	Capacitor polyester 10 nF \pm 10% 250V	Philips	2222 342 45103
C 312	Capacitor polyester 0.1 uF 250V	Efco	PMT (new type)
C 313	Capacitor polyester 0.1 uF 250V	Efco	PMT (new type)
C 314	Not used		
C 315	Capacitor ceramic 22 pF \pm 10% 400V	Ferroperm	9/0112,9
C 316	Capacitor polystyrene 422 pF \pm 1% 250V	Philips	2222 426 44221
C 317	Capacitor polystyrene 180 pF \pm 2% 500V	Philips	2222 427 31801
C 318	Capacitor trimmer 4 - 38 pF	Dau-Tefl.	109.3901.038
C 319	Capacitor trimmer 4 - 38 pF	Dau-Tefl.	109.3901.038
C 320	Capacitor trimmer 4 - 38 pF	Dau-Tefl.	109.3901.038
C 321	Capacitor trimmer 4 - 38 pF	Dau-Tefl.	109.3901.038
C 322	Capacitor polystyrene 1300pF \pm 1% 250V	Philips	2222 426 41302
C 323	Capacitor polystyrene 560 pF \pm 1% 250V	Philips	2222 426 45601
C 324	Capacitor polystyrene 412 pF \pm 1% 250V	Philips	2222 426 44121
C 325	Capacitor polystyrene 470 pF \pm 1% 250V	Philips	2222 426 44701
C 326	Capacitor polystyrene 2200pF \pm 1%	Philips	2222 425 42202
C 327	Capacitor polystyrene 2200pF \pm 1%	Philips	2222 425 42202
C 328	Capacitor polyester 0.1 uF 250V	Efco	PMT (new type)
C 329	Capacitor polyester 0.1 uF 250V	Efco	PMT (new type)
C 330	Capacitor polyester 0.1 uF 250V	Efco	PMT (new type)
C 331	Capacitor polyester 0.1 uF 250V	Efco	PMT (new type)
C 332	Capacitor polyester 0.1 uF 250V	Efco	PMT (new type)
C 333	Capacitor polyester 0.1 uF 250V	Efco	PMT (new type)
C 334	Capacitor polystyrene 3300pF \pm 1% 125V	Philips	2222 425 43302
C 335	Capacitor polyester 0.1 uF 250V	Efco	PMT (new type)
D 301	Diode	Texas/Sie.	1S921/1N4148
D 302	Diode	Texas/Sie.	1S921/1N4148
D 303	Diode	Texas/Sie.	1S921/1N4148

a

CRYSTAL SECTION R103 R104 R105 R106 R110 R115

Symbol	Description		Manufact.	
C 201	Capacitor trimmer 2 - 18 pF	teflon	Dau	107.2901.018
C 202	Capacitor ceramic 22 pF \pm 5%	NPO	Ferroperm	9/0112.9 - 400V
C 203	Capacitor trimmer 2 - 18 pF	teflon	Dau	107.2901.018
C 204	Capacitor ceramic 22 pF \pm 5%	NPO	Ferroperm	9/0112.9 - 400V
C 205	Capacitor trimmer 2 - 18 pF	teflon	Dau	107.2901.018
C 206	Capacitor ceramic 22 pF \pm 5%	NPO	Ferroperm	9/0112.9 - 400V
C 207	Capacitor trimmer 2 - 18 pF	teflon	Dau	107.2901.018
C 208	Capacitor ceramic 22 pF \pm 5%	NPO	Ferroperm	9/0112.9 - 400V
C 209	Capacitor trimmer 2 - 18 pF	teflon	Dau	107.2901.018
C 210	Capacitor ceramic 22 pF \pm 5%	NPO	Ferroperm	9/0112.9 - 400V
C 211	Capacitor trimmer 2 - 18 pF	teflon	Dau	107.2901.018
C 212	Capacitor ceramic 22 pF \pm 5%	NPO	Ferroperm	9/0112.9 - 400V
C 213	Capacitor trimmer 2 - 18 pF	teflon	Dau	107.2901.018
C 214	Capacitor ceramic 22 pF \pm 5%	NPO	Ferroperm	9/0112.9 - 400V
C 215	Capacitor trimmer 2 - 18 pF	teflon	Dau	107.2901.018
C 216	Capacitor ceramic 22 pF \pm 5%	NPO	Ferroperm	9/0112.9 - 400V
C 217	Capacitor trimmer 2 - 18 pF	teflon	Dau	107.2901.018
C 218	Capacitor ceramic 22 pF \pm 5%	NPO	Ferroperm	9/0112.9 - 400V
C 219	Capacitor trimmer 2 - 18 pF	teflon	Dau	107.2901.018
C 220	Capacitor ceramic 22 pF \pm 5%	NPO	Ferroperm	9/0112.9 - 400V
C 221	Capacitor trimmer 2 - 18 pF	teflon	Dau	107.2901.018
C 222	Capacitor ceramic 22 pF \pm 5%	NPO	Ferroperm	9/0112.9 - 400V
C 223	Capacitor trimmer 2 - 18 pF	teflon	Dau	107.2901.018
C 224	Capacitor ceramic 22 pF \pm 5%	NPO	Ferroperm	9/0112.9 - 400V

a

AM - FILTER R103 R104 R105 R106 R110 R111 R112 R114 R115

Symbol	Description	Manufact.	
C 401	Capacitor polystyrene 1000pF \pm 2% 125V	Philips	2222 425 31002
C 402	Capacitor polyester 0.1 uF \pm 10% 250V	Efco	PMT
C 403	Capacitor ceramic 8.2 pF \pm 0.5pF NPO	Ferroperm	9/0112.9
C 404	Capacitor polystyrene 1000pF \pm 2% 200V	Rifa	PFE 216
C 405	Capacitor ceramic 5.6 pF \pm 0.5pF NPO	Ferroperm	9/0112.9 - 400V
C 406	Capacitor polystyrene 1000pF \pm 2% 200V	Rifa	PFE 216
C 407	Capacitor ceramic 4.7 pF \pm 0.5pF NPO	Ferroperm	9/0112.9 - 400V
C 408	Capacitor polystyrene 1000pF \pm 2% 200V	Rifa	PFE 216
C 409	Capacitor ceramic 8.2 pF \pm 0.5pF NPO	Ferroperm	9/0112.9 - 400V
C 410	Capacitor polyester 0.1 uF \pm 10% 250V	Efco	PMT
C 411	Capacitor polystyrene 1000pF \pm 2% 200V	Rifa	PFE 216
C 412	Capacitor polyester 0.1 uF \pm 10% 250V	Efco	PMT
C 413	Capacitor polyester 0.1 uF \pm 10% 250V	Efco	PMT
D 401	Diode	Philips	BA 182
D 402	Diode	Philips	BA 182
L 401	Coil AM filter	S.P.	Drg.no. TL 144
L 402	Coil AM filter	S.P.	Drg.no. TL 003
L 403	Coil AM filter	S.P.	Drg.no. TL 003
L 404	Coil AM filter	S.P.	Drg.no. TL 003
L 405	Coil AM filter	S.P.	Drg.no. TL 014
R 401	Not used		
R 402	Resistor 1 K ohm 0.33W	Philips	2322 101 33102
R 403	Resistor 10 K ohms 0.33W	Philips	2322 101 33103
R 404	Resistor 15 K ohms 0.33W	Philips	2322 101 33153
R 405	Resistor 100 ohms 0.33W	Philips	2322 101 33101
R 406	Resistor 470 ohms 0.33W	Philips	2322 101 33471
R 407	Resistor 3.3K ohms 0.33W	Philips	2322 101 33332
R 408	Resistor 47 ohms 0.33W	Philips	2322 101 33479
R 409	Resistor 330 ohms 0.33W	Philips	2322 101 33331
R 410	Resistor 6.8K ohms 0.33W	Philips	2322 101 33682
T 401	Transistor FET, N-channel	Texas	TIS 88A

b BANDS SECTION R104 R105 R106 R110 L301

<i>Symbol</i>	<i>Description</i>	<i>Manufact.</i>	
L 301	Aerial coil SW	S.P.	Drg.no. TL 007
L 302	Aerial coil MW	S.P.	Drg.no. TL 182
L 303	Aerial coil LW	S.P.	Drg.no. TL 180
L 304	Aerial coil NW	S.P.	Drg.no. TL 181
L 305	Mixer transformer	S.P.	Drg.no. TL 012
L 306	Osc. transformer	S.P.	Drg.no. TL 078
L 307	Osc. coil SW	S.P.	Drg.no. TL 011
L 308	Osc. coil MW	S.P.	Drg.no. TL 185
L 309	Osc. coil LW	S.P.	Drg.no. TL 183
L 310	Osc. coil NW	S.P.	Drg.no. TL 184
L 311	IF trap	S.P.	Drg.no. TL 013
P 301	Potentiometer trimmer	2.2 K ohms	Philips 2322 410 43305
P 302	Potentiometer trimmer	4.7 K ohms	Philips 2322 410 43306
R 301	Resistor	2.2 K ohms 0.33W	Philips 2322 101 33222
R 302	Resistor	2.2 K ohms 0.33W	Philips 2322 101 33222
R 303	Resistor	220 ohms 0.33W	Philips 2322 101 33221
R 304	Resistor	1 K ohm 0.33W	Philips 2322 101 33102
R 305	Resistor	3.3 K ohms 0.33W	Philips 2322 101 33332
R 306	Resistor	1 K ohm 0.33W	Philips 2322 101 33102
R 307	Resistor	12 K ohms 0.33W	Philips 2322 101 33123
R 308	Resistor	15 K ohms 0.33W	Philips 2322 101 33153
R 309	Resistor	220 ohms 0.33W	Philips 2322 101 33221
R 310	Resistor	1.8 K ohms 0.33W	Philips 2322 101 33182
R 311	Resistor	22 K ohms 0.33W	Philips 2322 101 33223
R 312	Resistor	100 K ohms 0.33W	Philips 2322 101 33104
R 313	Resistor	6.8 K ohms 0.33W	Philips 2322 101 33682
R 314	Resistor	220 ohms 0.33W	Philips 2322 101 33221
R 315	Resistor	8.2 K ohms 0.33W	Philips 2322 101 33822
S 301	Push-button for PW	4+6 Switch	Petrick Sketch 70624/1
T 301	Transistor	FET , N-channel	Texas TIS 88A
T 302	Transistor	FET , N-channel	Texas TIS 88A
T 303	Transistor	FET , N-channel	Texas TIS 88A
T 304	Transistor		Siemens BC 147A
T 305	Transistor	FET , N-channel	Texas TIS 88A

a SSB DETECTOR SECTION R103 R104 R105 R106 R110 R111 R112 R115

Symbol	Description	Manufact.	
C 601	Capacitor polyester 0.1 uF $\pm 10\%$ 250V	Efco	PMT
C 602	Capacitor polystyrene 120 pF $\pm 2\%$ 500V	Philips	2222 427 31201
C 603	Capacitor trimmer 2 - 18 pF teflon	Dau	107.2901.018
C 604	Capacitor ceramic 12 pF $\pm 5\%$ NPO	Ferroperm	9/0112.9 - 400V
C 605	Capacitor polystyrene 180 pF $\pm 2\%$ 500V	Philips	2222 427 31801
C 606	Capacitor polystyrene 180 pF $\pm 2\%$ 500V	Philips	2222 427 31801
C 607	Capacitor polyester 0.1 uF $\pm 10\%$ 250V	Efco	PMT
C 608	Capacitor polyester 0.1 uF $\pm 10\%$ 250V	Efco	PMT
C 609	Capacitor polyester 0.1 uF $\pm 10\%$ 250V	Efco	PMT
C 610	Capacitor polyester 0.1 uF $\pm 10\%$ 250V	Efco	PMT
C 611	Capacitor polystyrene 120 pF $\pm 2\%$ 500V	Philips	2222 427 31201
C 612	Capacitor trimmer 2 - 18 pF teflon	Dau	107.2901.018
C 613	Capacitor ceramic 12 pF $\pm 5\%$ NPO	Ferroperm	9/0112.9 - 400V
C 614	Capacitor polystyrene 180 pF $\pm 2\%$ 500V	Philips	2222 427 31801
C 615	Capacitor polystyrene 180 pF $\pm 2\%$ 500V	Philips	2222 427 31801
C 616	Capacitor polyester 0.1 uF $\pm 10\%$ 250V	Efco	PMT
C 617	Capacitor polystyrene 1000pF $\pm 2\%$ 125V	Philips	2222 425 31002
C 618	Capacitor polyester 0.1 uF $\pm 10\%$ 250V	Efco	PMT
C 619	Capacitor tantalum 4.7 uF 35V	Ero	ETP 2
C 620	Capacitor tantalum 10 uF 25V	Ero	ETP 3
C 621	Capacitor polystyrene 2200pF $\pm 2\%$ 125V	Philips	2222 425 32202
C 622	Capacitor polystyrene 2200pF $\pm 2\%$ 125V	Philips	2222 425 22202
C 623	Capacitor polyester 0.1 uF $\pm 10\%$ 250V	Efco	PMT
C 624	Capacitor polyester 0.1 uF $\pm 10\%$ 250V	Efco	PMT
D 601	Diode variable capacitance	Philips	BB 106
D 602	Diode zener	Philips	BZX79/C8V2
D 603	Diode variable capacitance	Philips	BB 106
R 601	Resistor 10 K ohms 0.33W	Philips	2322 101 33103
R 602	Resistor 10 K ohms 0.33W	Philips	2322 101 33103
R 603	Resistor 27 K ohms 0.33W	Philips	2322 101 33273
R 604	Resistor 4.7K ohms 0.33W	Philips	2322 101 33472
R 605	Resistor 10 K ohms 0.33W	Philips	2322 101 33103
R 606	Resistor 820 ohms 0.33W	Philips	2322 101 33821
R 607	Resistor 15 ohms 0.33W	Philips	2322 101 33159
R 608	Resistor 100 ohms 0.33W	Philips	2322 101 33101
R 609	Resistor 390 ohms 0.33W	Philips	2322 101 33391

a

SSB FILTER R103 R104 R105 R106 R110 R111 R112 R115

Symbol	Description	Manufact.	
C 501	Capacitor polyester 0.1 uF $\pm 10\%$ 250V	Efco	PMT
C 502	Capacitor polystyrene 1800pF $\pm 2\%$ 125V	Philips	2222 425 31802
C 503	Capacitor polystyrene 2200pF $\pm 2\%$ 125V	Philips	2222 425 32202
C 504	Capacitor polystyrene 1800pF $\pm 2\%$ 125V	Philips	2222 425 31802
C 505	Capacitor polystyrene 2200pF $\pm 2\%$ 125V	Philips	2222 425 32202
C 506	Capacitor polyester 0.1 uF $\pm 10\%$ 250V	Efco	PMT
C 507	Capacitor polyester 0.1 uF $\pm 10\%$ 250V	Efco	PMT
C 508	Capacitor polyester 0.1 uF $\pm 10\%$ 250V	Efco	PMT
D 501	Diode	Philips	BA 182
D 502	Diode	Philips	BA 182
FL501	Crystal filter 600 KHz	NDK	YF 600
L 501	SSB filter coil	S.P.	Drg.no. TL 013
L 502	SSB filter coil	S.P.	Drg.no. TL 013
R 501	Resistor 39 K ohms 0.33W	Philips	2322 101 33393
R 502	Resistor 1 K ohm 0.33W	Philips	2322 101 33102
R 503	Resistor 470 ohms 0.33W	Philips	2322 101 33471
R 504	Resistor 56 K ohms 0.33W	Philips	2322 101 33563
R 505	Resistor 120K ohms 0.33W	Philips	2322 101 33124
R 506	Resistor 3.3K ohms 0.33W	Philips	2322 101 33332
R 507	Resistor 47 ohms 0.33W	Philips	2322 101 33479
R 508	Resistor 330 ohms 0.33W	Philips	2322 101 33331
T 501	Transistor FET N-channel	Texas	TIS 88A

a

IF SECTION R103 R104 R105 R106 R110 R114 R115

Symbol	Description	Manufact.	
C701	Capacitor polystyrene 560 pF \pm 2%	Philips	2222 425 35601
C702	Capacitor tantalum 10 uF	Ero	ETP 3F
C703	Capacitor polyester 0.1 uF \pm 10%	Efco	PMT
C704	Capacitor polystyrene 1500pF \pm 2%	Philips	2222 425 31502
C705	Capacitor polystyrene 3300pF \pm 2%	Philips	2222 425 33302
C706	Capacitor polyester 0.1 uF \pm 10%	Efco	PMT
C707x	Capacitor polyester 0.1 uF \pm 10%	Efco	PMT
C707xx	Capacitor ceramic 47 pF \pm 5%	Ferroperm	9/0112.3 insul.
C708	Capacitor polystyrene 1500pF \pm 2%	Philips	2222 425 31502
C709	Capacitor polystyrene 3300pF \pm 2%	Philips	2222 425 33302
C710	Capacitor polyester 0.1 uF \pm 10%	Efco	PMT
C711	Not used		
C712	Capacitor polystyrene 1000pF \pm 2%	Philips	2222 425 31002
C713	Capacitor polystyrene 2200pF \pm 2%	Philips	2222 425 32202
C714	Capacitor tantalum 10 uF	Ero	ETP 3F
C715	Capacitor tantalum 10 uF	Ero	ETP 3F
C716	Capacitor polystyrene 2200pF \pm 2%	Philips	2222 425 32202
C717	Capacitor polystyrene 2200pF \pm 2%	Philips	2222 425 32202
C718	Capacitor polyester 0.1 uF \pm 10%	Efco	PMT
x	Not used in R114 and R115		
xx	Only in R114 and R115		
L701	IF coil	S.P.	Drg.no. TL 013
L702	IF coil	S.P.	Drg.no. TL 013
L703	IF coil	S.P.	Drg.no. TL 015
R701	Resistor 1 K ohm	Philips	2322 101 33102
R702	Resistor 10 K ohms	Philips	2322 101 33103
R703	Resistor 1 K ohm	Philips	2322 101 33102
R704	Resistor 100 ohms	Philips	2322 101 33101
R705	Resistor 470 ohms	Philips	2322 101 33471
R706	Resistor 1.2K ohms	Philips	2322 101 33122
R707	Resistor 1 K ohm	Philips	2322 101 33102
R708	Resistor 470 ohms	Philips	2322 101 33471
R709	Resistor 47 ohms	Philips	2322 101 33479
R710	Resistor 1.2K ohms	Philips	2322 101 33122
R711	Resistor 6.8K ohms	Philips	2322 101 33682
R712	Resistor 12 K ohms	Philips	2322 101 33123

a

SSB DETECTOR SECTION R103 R104 R105 R106 R110 R111 R112 R115

Symbol	Description			Manufact.	
R 610	Resistor	1 K ohm	0.33W	Philips	2322 101 33102
R 611	Resistor	10 K ohms	0.33W	Philips	2322 101 33103
R 612	Resistor	27 K ohms	0.33W	Philips	2322 101 33273
R 613	Resistor	4.7K ohms	0.33W	Philips	2322 101 33472
R 614	Resistor	10 K ohms	0.33W	Philips	2322 101 33103
R 615	Resistor	820 ohms	0.33W	Philips	2322 101 33821
R 616	Resistor	15 ohms	0.33W	Philips	2322 101 33159
R 617	Resistor	1 K ohm	0.33W	Philips	2322 101 33102
R 618	Resistor	1.5K ohms	0.33W	Philips	2322 101 33152
R 619	Resistor	470K ohms	0.33W	Philips	2322 101 33474
R 620	Resistor	4.7K ohms	0.33W	Philips	2322 101 33472
R 21	Resistor	10 K ohms	0.33W	Philips	2322 101 33103
R 622	Resistor	1 K ohm	0.33W	Philips	2322 101 33102
R 623	Resistor	22 K ohms	0.33W	Philips	2322 101 33223
R 624	Resistor	2.7K ohms	0.33W	Philips	2322 101 33272
R 625	Resistor	2.7K ohms	0.33W	Philips	2322 101 33272
R 626	Resistor	1 K ohm	0.33W	Philips	2322 101 33102
L 601	Mixer coil (clarifier)			S.P.	Drg.no. TL 017
T 601	Transistor	NPN		Siemens	BC 147A
T 602	Transistor	NPN		Siemens	BC 147A
T 603	Transistor	NPN		Siemens	BC 147A
T 604	Transistor	NPN		Siemens	BC 147A
T 05	Transistor	FET N - channel		Texas	TIS 88A
X 601	Crystal HC/6/W	6.7 MHz		KVG	
X 602	Crystal HC/6/W	7.3 MHz		KVG	

a

AGC SECTION R103 R104 R105 R106 R110 R111 R112 R114 R115

Symbol	Description	Manufact.	
C 801	Capacitor electrolytic 100 uF 25V	Siemens	B41283-B5107-T
C 802	Capacitor electrolytic 22 uF 40V	Siemens	B41283-B7226-T
C 803	Capacitor polyester 0.1 uF 250V	Efco	PMT
C 804	Capacitor polystyrene 330 pF \pm 2% 250V	Philips	2222 426 33301
C 805	Capacitor polyester 0.1 uF 250V	Efco	PMT
C 806	Capacitor tantalum 10 uF 25V	Ero	ETP 3
C 807	Capacitor polystyrene 3300pF \pm 2% 125V	Philips	2222 425 33302
C 808	Capacitor polystyrene 120 pF \pm 2% 500V	Philips	2222 427 31201
C 809	Capacitor polyester 0.1 uF 250V	Efco	PMT
C 810	Capacitor polystyrene 1000pF \pm 2% 125V	Philips	2222 425 31002
C 811	Capacitor polyester 0.1 uF 250V	Efco	PMT
C 812	Capacitor polyester 0.1 uF 250V	Efco	PMT
C 813	Capacitor polyester 0.1 uF 250V	Efco	PMT
C 814	Capacitor ceramic 1000pF +80/-20% 40V	Ferroperm	9/0129.8 insul.
C 815	Capacitor ceramic 100 pF \pm 20% 63V	Ferroperm	9/0116.8 insul.
D 801	Diode	Texas/Sie.	1S921/1N4148
D 802	Diode	Texas/Sie.	1S921/1N4148
D 803	Diode	Texas/Sie.	1S921/1N4148
D 804	Diode	Texas/Sie.	1S921/1N4148
D 805	Diode	Texas/Sie.	1S921/1N4148
D 806	Diode	Texas/Sie.	1S921/1N4148
D 807	Diode, stabistor 2.8V \pm 5%	Philips	BZX75 C2V8
D 808	Diode	Texas/Sie.	1S921/1N4148
D 809	Diode	Texas/Sie.	1S921/1N4148
L 801	ACC coil	S.P.	Drg.no. TL 016
P 801	Potentiometer 2.2 K ohms	Philips	2322 410 43305
P 802	Potentiometer 1 M ohm	Ruwido	S 52/S 52K
P 803	Potentiometer 470 ohms	Philips	2322 410 43303

IF SECTION R103 R104 R105 R106 R110 R114 R115

Description			Manufact.	
Resistor	1 K ohm	0.33W	Philips	2322 101 33102
Resistor	1.8K ohms	0.33W	Philips	2322 101 33182
Resistor	330 ohms	0.33W	Philips	2322 101 33331
Resistor	68 K ohms	0.33W	Philips	2322 101 33683
Resistor	18 K ohms	0.33W	Philips	2322 101 33183
Resistor	150K ohms	0.33W	Philips	2322 101 33154
Resistor	1 K ohm	0.33W	Philips	2322 101 33102
Resistor	18 K ohms	0.33W	Philips	2322 101 33183
Resistor	100K ohms	0.33W	Philips	2322 101 33104
Resistor	15 K ohms	0.33W	Philips	2322 101 33153
Resistor	100 ohms	0.33W	Philips	2322 101 33101
Potentiometer trimmer 10 K ohms			Philips	2322 410 43307
Transistor			Siemens	BC 148C
Transistor			Siemens	BC 157A
Transistor			Siemens	BF 167
Transistor			Siemens	BF 167
Transistor			Siemens	BF 167
Transistor			Siemens	BC 147A

a

AUDIO AMP R103 R104 R105 R106 R110 R111 R112 R115

Symbol	Description	Manufact.	
C 901	Capacitor polyester 0.1 uF $\pm 20\%$ 250V	Efco	PMT
C 902	Capacitor tantalum 4.7 uF 35V	Ero	ETP 2
C 903	Capacitor tantalum 0.1 uF 35V	Ero	ETP 1
C 904	Capacitor electrolytic 100 uF 25V	Siemens	B41283-A5107-Z
C 905	Capacitor electrolytic 100 uF 25V	Siemens	B41283-A5107-Z
C 906	Capacitor polyester 0.01 uF $\pm 10\%$ 250V	Philips	2222 342 45103
C 907	Capacitor electrolytic 1000uF 16V	Siemens	B41010-A4108-Z
C 908	Capacitor polyester 0.1 uF $\pm 20\%$ 250V	Efco	PMT
D 901	Diode 27 V $\pm 5\%$ 1W	Motorola	1N 4750A
D 902	Diode 27 V $\pm 5\%$ 1W	Motorola	1N 4750A
P 901	Potentiometer trimmer 500 ohms $\pm 10\%$	Ruwido	S 52K
R 901	Resistor 100 K ohms 0.33W	Philips	2322 101 33104
R 902	Resistor 8.2 K ohms 0.33W	Philips	2322 101 33822
R 903	Resistor 100 K ohms 0.33W	Philips	2322 101 33104
R 904	Resistor 560 ohms 0.33W	Philips	2322 101 33561
R 905	Resistor 8.2 K ohms 0.33W	Philips	2322 101 33822
R 906	Resistor 27 K ohms 0.33W	Philips	2322 101 33273
R 907	Resistor 56 K ohms 0.33W	Philips	2322 101 33563
R 908	Resistor 47 ohms 0.33W	Philips	2322 101 33479
R 909	Resistor 820 ohms 0.33W	Philips	2322 101 33821
R 910	Resistor 820 ohms 0.33W	Philips	2322 101 33821
R 911	Resistor 220 ohms 0.33W	Philips	2322 101 33221
R 912	Resistor NTC 33 ohms 1W	Philips	2322 610 11339
R 913	Resistor 22 ohms 0.33W	Philips	2322 101 33229
R 914	Resistor $\pm 20\%$ 0.47 ohms 0.7W	Resista	RN 3
R 915	Resistor 560 ohms 0.33W	Philips	2322 101 33561
R 916	Resistor 56 ohms 0.33W	Philips	2322 101 33569
R 917	Resistor 560 ohms 0.33W	Philips	2322 101 33561

a AGC SECTION R103 R104 R105 R106 R110 R111 R112 R114 R115

Symbol	Description	Manufact.	
R 800	Resistor 1.8 K ohms 0.33W	Philips	2322 101 33182
R 801	Resistor 3.3 K ohms 0.33W	Philips	2322 101 33332
R 802	Resistor 27 K ohms 0.33W	Philips	2322 101 33273
R 803	Resistor 100 ohms 0.33W	Philips	2322 101 33101
R 804	Resistor 560 ohms 0.33W	Philips	2322 101 33561
R 805	Resistor 1 M ohm 0.33W	Philips	2322 101 33105
R 806	Resistor 100 ohms 0.33W	Philips	2322 101 33101
R 807	Resistor 100 K ohms 0.33W	Philips	2322 101 33104
R 808	Resistor 2.2 K ohms 0.33W	Philips	2322 101 33222
R 809	Resistor 3.3 K ohms 0.33W	Philips	2322 101 33332
R 810	Resistor 1.5 K ohms 0.33W	Philips	2322 101 33152
R 811	Resistor 8.2 K ohms 0.33W	Philips	2322 101 33822
R 812	Resistor 100 ohms 0.33W	Philips	2322 101 33101
R 813	Resistor 1 M ohm 0.33W	Philips	2322 101 33105
R 814	Resistor 100 K ohms 0.33W	Philips	2322 101 33104
R 815	Resistor 3.9 K ohms 0.33W	Philips	2322 101 33392
R 816	Resistor 220 ohms 0.33W	Philips	2322 101 33221
R 817	Resistor 33 K ohms 0.33W	Philips	2322 101 33333
T 801	Transistor	Siemens	BC 148C
T 802	Transistor	Siemens	BC 157A
T 803	Transistor	Siemens	BC 147A
T 804	Transistor	Siemens	BC 148C
T 805	Transistor	Ph/Sie.	BF 199/BF 597

b

CHASSISMONTAGE R103 R104 R105 R106 R110 C1001

Symbol	Description	Manufact.	
C1001	Capacitor variable 2x518 pF	Jackson Brothers	5084/2/518
C1002	Capacitor polyester 10 nF 1500V	Ero	KP1832 310
C1003	Capacitor polyester 10 nF 1500V	Ero	KP1832 310
C1004	Capacitor polyester 10 nF 1500V	Ero	KP1832 310
C1005	Capacitor polyester 10 nF 1500V	Ero	KP1832 310
C1006	Capacitor polyester 0.1uF 250V	Efco	PMT (short
C1007	Capacitor polyester 0.1uF 250V	Efco	PMT (short
C1008	Capacitor polyester 0.1uF 250V	Efco	PMT (short
C1009	Capacitor polyester 56 nF ± 10% 250V	Philips	2222 342 45
C1010	Capacitor polyester 10 nF ± 10% 250V	Philips	2222 342 45
CH1001	Filter choke 2x5 mHy	Siemens	B82791-A2
CH1002	Filter choke 250 mHy	S.P.	Drg.no. T
CH1003	Filter choke 250 mHy	S.P.	Drg.no. T
D1001	Diode	Tex./Sie.	1S921/1N
F1001	Fuse 1.6A slow blow 5x20 mm	E1.V.	
F1002	Fuse 1.6A slow blow 5x20 mm	E1.V.	
GL1001	Neon lamp	Siemens	B1-C90-Q
J1001	Aerial socket	Bell & Lee	L734/5
J1002	DF socket	Hirschmann	Meb 60H
J1003	Phone jack and loudspeaker jack	Cliff	Type S1
J1004	Power socket	Hirschmann	Mesei 60
LA1001	Dial lamp 12V 0.1A	Philips	8003 DIM.X
L1001	AF filtercoil	S.P.	Drg.no. T
LS1001 ^x	Loudspeaker 8 ohms	Videbaek	21/8 TV - 1
x	Only R105		

AUDIO AMP R103 R104 R105 R106 R110 R111 R112 R115

<i>Description</i>	<i>Manufact.</i>	
nsistor	Siemens	BC 148C
nsistor	Siemens	BC 147A
nsistor - matched pair	Miniwatt	2 x AD 162
nsformer - driver	Tradania	1805

a 12/24V DC POWER SUPPLY R103 R104 R105 R106 R110 R111 R112 R11

Symbol	Description	Manufact.	
C 1101	Capacitor electrolytic 1000uF 16V	Siemens	B41010-A
C 1102	Capacitor electrolytic 1000uF 16V	Siemens	B41010-A
C 1103	Capacitor electrolytic 100 uF 25V	Siemens	B41283-A
C 1104	Capacitor polyester 0.22uF 100V	Philips	2222 342
C 1105	Capacitor electrolytic 470 uF 35V	Siemens	B41010-A
C 1106	Capacitor electrolytic 100 uF 25V	Siemens	B41283-A
C 1107	Capacitor polyester 0.1 uF 250V	Efco	PMT (sho
C 1108	Capacitor polyester 0.1 uF 250V	Efco	PMT (sho
C 1109	Capacitor polyester 0.1 uF 250V	Efco	PMT (sho
C 1110	Capacitor polyester 0.1 uF 250V	Efco	PMT (sho
D 1101	Diode	Motorola	1N4002
D 1102	Diode zener 13 V 2W	Motorola	1N5366B
D 1103	Diode bridge connection	Philips	BY 179
D 1104	Diode zener 9.1V 400mW	Philips	BZX79 C9
D 1105	Diode zener 9.1V P 400mW	Philips	BZX79 C9
D 1106	Diode zener 39 V 5W	Motorola	1N5366B
R 1101	Resistor 2.2 ohms 4W	Vitrohm	206 - 0
R 1102	Resistor 330 ohms 4.2W	Philips	2322 330
R 1103	Resistor 1.5 ohms 1W	Vitrohm	253 - 0
R 1104	Resistor 1.5 ohms 1W	Vitrohm	253 - 0
R 1105	Resistor 270 ohms 1W	Vitrohm	107 - 0
R 1106	Resistor 2.2 ohms 4W	Vitrohm	206 - 0
R 1107	Resistor 56 ohms 0.5W	Philips	2322 212
R 1108	Resistor 1.8Kohms 0.33W	Philips	2322 101
R 1109	Resistor 220 ohms 0.33W	Philips	2322 101
R 1110	Resistor 22 ohms 0.33W	Philips	2322 101
R 1111	Resistor 22 ohms 0.33W	Philips	2322 101
S 1101	Voltage switch	Mec	SMA - 4
x	Not used in R111/R112		

a

CHASSISMONTAGE R103 R104 R105 R106 R110

Symbol	Description	Manufact.	
M1001	Meter - nonimeter	Elmatok	MG 20E
P1001	Potentiometer 10 K ohms lin.	Lesa	Drg.no. M 008
P1002	Potentiometer 10 K ohms lin.	Lesa	Drg.no. M 008
P1003	Potentiometer 100K ohms w/switch	Lesa	Drg.no. M 010
P1004	Potentiometer 330 ohms wire wound	Philips	2322 003 90027
R1001	Resistor 2.2K ohms 0.33W	Philips	2322 101 33222
R1002	Resistor 22 K ohms 0.33W	Philips	2322 101 33223
R1003	Resistor 10 K ohms 0.33W	Philips	2322 101 33103
R1004	Resistor 10 ohms 0.33W	Philips	2322 101 33109
R1005	Resistor 39 ohms 0.33W	Philips	2322 101 33399
R1006	Resistor 470 ohms 0.33W	Philips	2322 101 33471
R1007	Resistor 1 K ohm 0.33W	Philips	2322 101 33102
R1008	Resistor 100K ohms 0.33W	Philips	2322 101 33104
R1009 ^x	Resistor 10 K ohms 0.33W	Philips	2322 101 33103
R1010 ^x	Resistor 10 K ohms 0.33W	Philips	2322 101 33103
RE1001	Relay	Siemens	V23016 B0005-A101
S1001	Switch 8 positions, 5 decks	MEC	OM 006F
S1003	Power switch part of P1003		
S1004	Loudspeaker switch	MEC	SMA - 4
S1006	Bands/channel switch	Petrick	Sketch 701120
S1007 ^x	Range shift switch	Petrick	Sketch 701120
TR1001	Output transformer	Tradania	1839
^x	R103Sp - R106Sp only		
^x	R110 Only		

12/24V DC POWER SUPPLY R103 R104 R105 R106 R110 R111 R112 R115

Symbol	Description	Manufact.	
C 1101	Capacitor electrolytic 1000uF 16V	Siemens	B41010-A4108-Z
C 1102	Capacitor electrolytic 1000uF 16V	Siemens	B41010-A4108-Z
C 1103	Capacitor electrolytic 100 uF 25V	Siemens	B41283-A5107-Z
C 1104	Capacitor polyester 0.22uF 100V	Philips	2222 342 24224
C 1105	Capacitor electrolytic 470 uF 35V	Siemens	B41010-A7477-Z
C 1106	Capacitor electrolytic 100 uF 25V	Siemens	B41283-A5107-Z
C 1107	Capacitor polyester 0.1 uF 250V	Efco	PMT (short)
C 1108	Capacitor polyester 0.1 uF 250V	Efco	PMT (short)
C 1109	Capacitor polyester 0.1 uF 250V	Efco	PMT (short)
C 1110	Capacitor polyester 0.1 uF 250V	Efco	PMT (short)
D 1101	Diode	Motorola	1N4002
D 1102	Diode zener 13 V 2W	Motorola	1N5350B
D 1103	Diode bridge connection	Philips	BY 179
D 1104	Diode zener 9.1V 400mW	Philips	BZX79 C9V1
D 1105	Diode zener 9.1V P 400mW	Philips	BZX79 C9V1
D 1106	Diode zener 39 V 5W	Motorola	1N5366B
R 1101	Resistor 2.2 ohms 4W	Vitrohm	206 - 0
R 1102	Resistor 330 ohms 4.2W	Philips	2322 330 22331
R 1103	Resistor 1.5 ohms 1W	Vitrohm	253 - 0
R 1104	Resistor 1.5 ohms 1W	Vitrohm	253 - 0
R 1105	Resistor 270 ohms 1W	Vitrohm	107 - 0
R 1106	Resistor 2.2 ohms 4W	Vitrohm	206 - 0
R 1107	Resistor 56 ohms 0.5W	Philips	2322 212 13569
R 1108	Resistor 1.8Kohms 0.33W	Philips	2322 101 33182
R 1109	Resistor 220 ohms 0.33W	Philips	2322 101 33221
R 1110	Resistor 22 ohms 0.33W	Philips	2322 101 33229
R 1111	Resistor 22 ohms 0.33W	Philips	2322 101 33229
S 1101*	Voltage switch	Mec	SMA - 4
x	Not used in R111/R112		

12/24V DC POWER SUPPLY R103 R104 R105 R106 R110 R111 R112 R115

Symbol	Description	Manufact.	
T 1101	Transistor	Siemens	BD 130
T 1102	Transistor	Siemens	BC 141-10
T 1103	Transistor	Siemens	BC 141-10
T 1104	Transistor	Siemens	BC 141-10
TR1101	Transformer	Tradania	1611 - 7101

a 110/220V AC POWER SUPPLY R103 R104 R105 R106 R107 R108 R109 R110 R111 R112 R113 R114 R115

Symbol	Description	Value	Power	Manufact.	Part No.
C 1201	Capacitor polyester	0.1 uF	250V	Efco	PMT 5000
C 1202	Capacitor electrolytic	470 uF	35V	Siemens	B412 1000-Z
C 1203	Capacitor electrolytic	100 uF	25V	Siemens	B412 1000-Z
C 1204	Capacitor polyester	0.1 uF	250V	Efco	PMT 5000
C 1205	Capacitor electrolytic	2200uF	35V	Siemens	B412 1000-T
C 1206	Capacitor polyester	0.022uF	250V	Philips	2222 1000-23
D 1201	Diode bridge connection			Philips	BY 100
D 1202	Diode bridge connection			Philips	BY 100
D 1203	Diode zener	9.1 V	400mW	Philips	BZX79 100
D 1204	Diode zener	9.1 V	400mW	Philips	BZX79 100
D 1205	Diode zener	5.6 V	400mW	Philips	BZX79 100
R 1201	Resistor	22 ohms	0.33W	Philips	2322 1000-29
R 1202	Resistor	1.8K ohms	0.33W	Philips	2322 1000-82
R 1203	Resistor	220 ohms	0.33W	Philips	2322 1000-21
R 1204	Resistor	2.2 ohms	4W	Vitrohm	2000
R 1205	Resistor	1.5K ohms	0.33W	Philips	2322 1000-52
R 1206	Not used				
R 1207	Resistor	1 K ohm	0.33W	Philips	2322 1000-02
R 1208	Resistor	1.5K ohms	0.33W	Philips	2322 1000-52
R 1209	Resistor	1.5K ohms	0.33W	Philips	2322 1000-52
S 1201	Voltage switch			Mec	SM 100
T 1201	Transistor			Siemens	BC 107
T 1202	Transistor			Siemens	BC 107
T 1203	Transistor			Siemens	BC 107
T 1204	Transistor			Motorola	2N105
TR1201	Transformer			Tradania	1000

CHANNEL TUNER SWII 4 - 9 MHz

R110 R112

Symbol	Description	Manufact.	
C 1301	Capacitor trimmer 7-120pF teflon	Dau	116.3901.120
C 1302	Capacitor ceramic 150 pF \pm 5% 250V	Ferroperm	9/0121.3 insul.
C 1303	Capacitor trimmer 4-38pF teflon	Dau	109.3901.038
C 1304	Capacitor ceramic 2.7 pF \pm 0.25pF	Ferroperm	9/0112.9 - 400V
C 1305	Capacitor trimmer 4-38pF teflon	Dau	109.3901.038
C 1306	Capacitor polystyrene 1000pF \pm 2% 125V	Philips	2222 425 31002
C 1307	Capacitor ceramic 220 pF \pm 5% 250V	Ferroperm	9/0121.3 insul.
C 1308	Capacitor polyester 0.1 uF 250V	Efco	PMT
C 1309	Capacitor polystyrene 330 pF \pm 2% 250V	Philips	2222 426 33901
C 1310	Capacitor polyester 0.1 uF 250V	Efco	PMT
C 1311	Capacitor polyester 0.1 uF 250V	Efco	PMT
C 1312	Capacitor polystyrene 1000pF \pm 2% 125V	Philips	2222 425 31002
C 1313	Capacitor polystyrene 390 pF \pm 2% 250V	Philips	2222 426 33901
C 1314	Capacitor ceramic 470 pF \pm 5% 250V	Ferroperm	9/0121.3 insul.
C 1315	Capacitor trimmer 4-38pF teflon	Dau	109.3901.038
C 1316	Capacitor polyester 1000pF \pm 2% 125V	Philips	2222 425 31002
C 1317	Capacitor polyester 0.1 uF 250V	Efco	PMT
C 1318	Capacitor polyester 0.1 uF 250V	Efco	PMT
C 1319	Capacitor polystyrene 560 pF \pm 2% 125V	Philips	2222 425 35601
C 1320	Capacitor polystyrene 390 pF \pm 2% 250V	Philips	2222 426 33901
C 1321	Capacitor polystyrene 560 pF \pm 2% 125V	Philips	2222 425 35601
C 1322	Capacitor polyester 0.1 uF 250V	Efco	PMT
C 1323	Capacitor polystyrene 560 pF \pm 2% 125V	Philips	2222 425 35601
C 1324	Capacitor polyester 0.1 uF 250V	Efco	PMT
C 1325	Capacitor electrolytic 100uF 25V	Siemens	B41283-A5107-Z
Ch. 1301	Choke coil 1 mH \pm 10%	Prahn	1580/9K
D 1301	Diode	Texas/Sie.	1S921/1N4148
D 1302	Diode	Texas/Sie.	1S921/1N4148
L 1301	Aerial coil 1	S.P.	Drg.no. TL 035
L 1302	Aerial coil 11	S.P.	Drg.no. TL 035
L 1303	RF coil	S.P.	Drg.no. TL 035
L 1304	Shunt coil 600 kHz	S.P.	Drg.no. TL 003

Symbol	Description	Manufac.
R 1300	Resistor 100K ohms	Philips
R 1301	Resistor 1 K ohm	Philips
R 1302	Resistor 680 ohms	Philips
R 1303	Resistor 47 ohms	Philips
R 1304	Resistor 1.8K ohms	Philips
R 1305	Resistor 47 ohms	Philips
R 1306	Resistor 470K ohms	Philips
R 1307	Resistor 2.7K ohms	Philips
R 1308	Resistor 220 ohms	Philips
R 1309	Resistor 680 ohms	Philips
R 1310	Resistor 33 ohms	Philips
R 1311	Resistor 10 K ohms	Philips
R 1312	Resistor 39 K ohms	Philips
R 1313	Resistor 1.5K ohms	Philips
R 1314	Resistor 1 K ohm	Philips
R 1315	Resistor 15 ohms	Philips
R 1316	Resistor 1.5K ohms	Philips
R 1317	Resistor 22 K ohms	Philips
R 1318	Resistor 22 K ohms	Philips
R 1319	Resistor 10 K ohms	Philips
R 1320	Resistor 18 K ohms	Philips
T 1301	Transistor	Siemens
T 1302	Transistor	Texas
T 1303	Transistor	Siemens
T 1304	Transistor	Siemens
T 1305	Transistor	Siemens
BF 167		Siemens
TIS 88A		Texas
BC 147A		Siemens
BC 147A		Siemens
BC 147A		Siemens
2322 101 33104	Philips	0.33W
2322 101 33102	Philips	0.33W
2322 101 33681	Philips	0.33W
2322 101 33479	Philips	0.33W
2322 101 33182	Philips	0.33W
2322 101 33479	Philips	0.33W
2322 101 33681	Philips	0.33W
2322 101 33479	Philips	0.33W
2322 101 33272	Philips	0.33W
2322 101 33221	Philips	0.33W
2322 101 33681	Philips	0.33W
2322 101 33339	Philips	0.33W
2322 101 33103	Philips	0.33W
2322 101 33393	Philips	0.33W
2322 101 33152	Philips	0.33W
2322 101 33102	Philips	0.33W
2322 101 33159	Philips	0.33W
2322 101 33152	Philips	0.33W
2322 101 33152	Philips	0.33W
2322 101 33223	Philips	0.33W
2322 101 33223	Philips	0.33W
2322 101 33223	Philips	0.33W
2322 101 33103	Philips	0.33W
2322 101 33183	Philips	0.33W

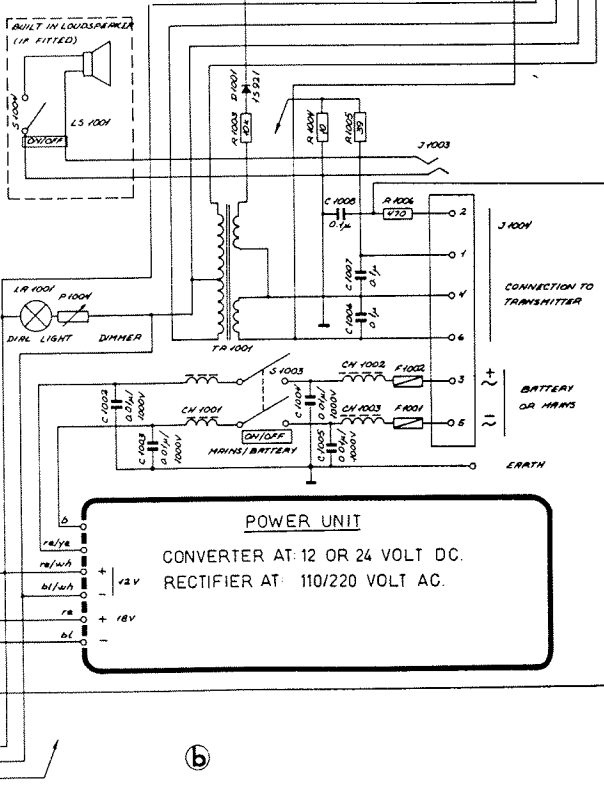
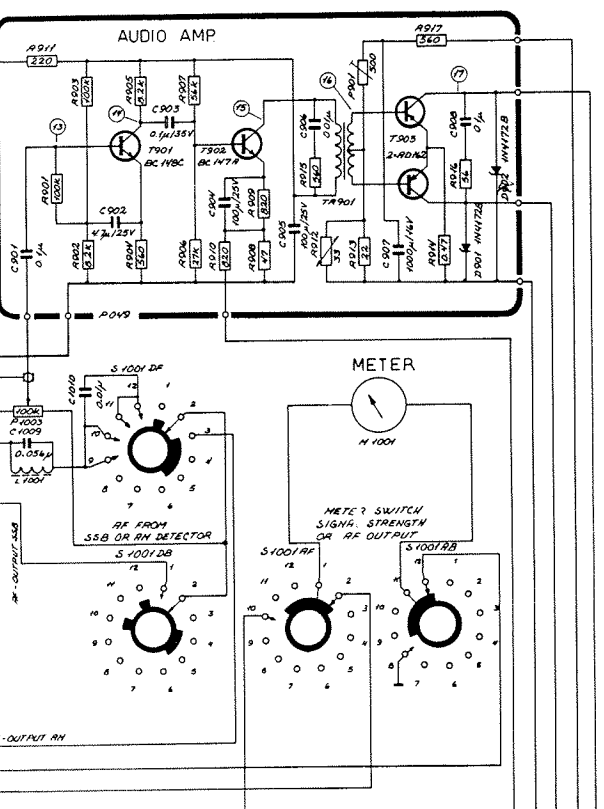
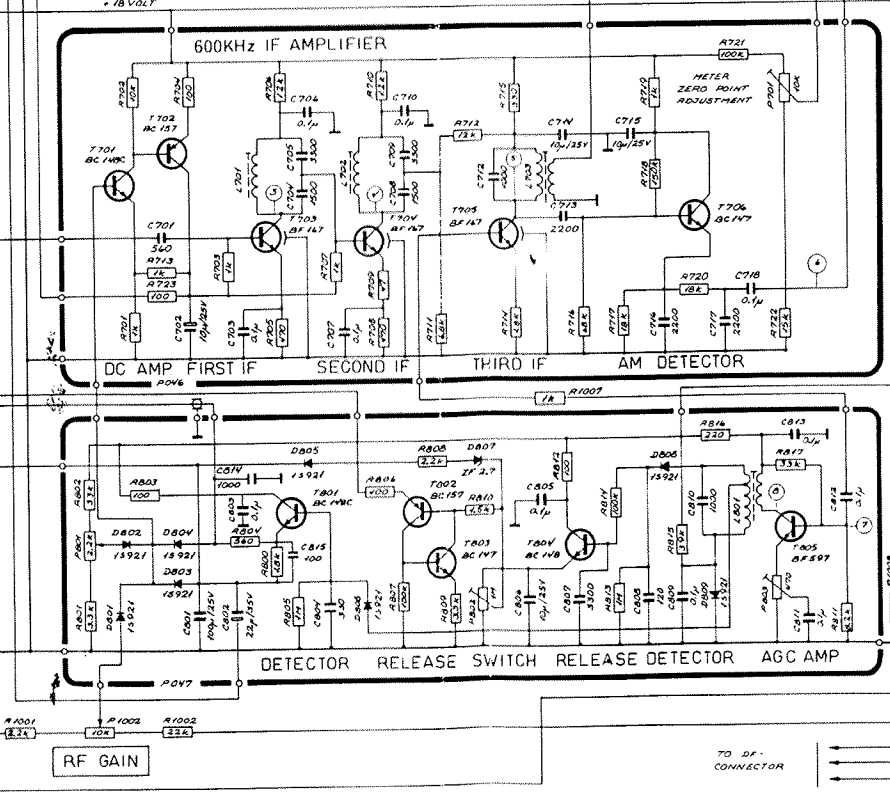
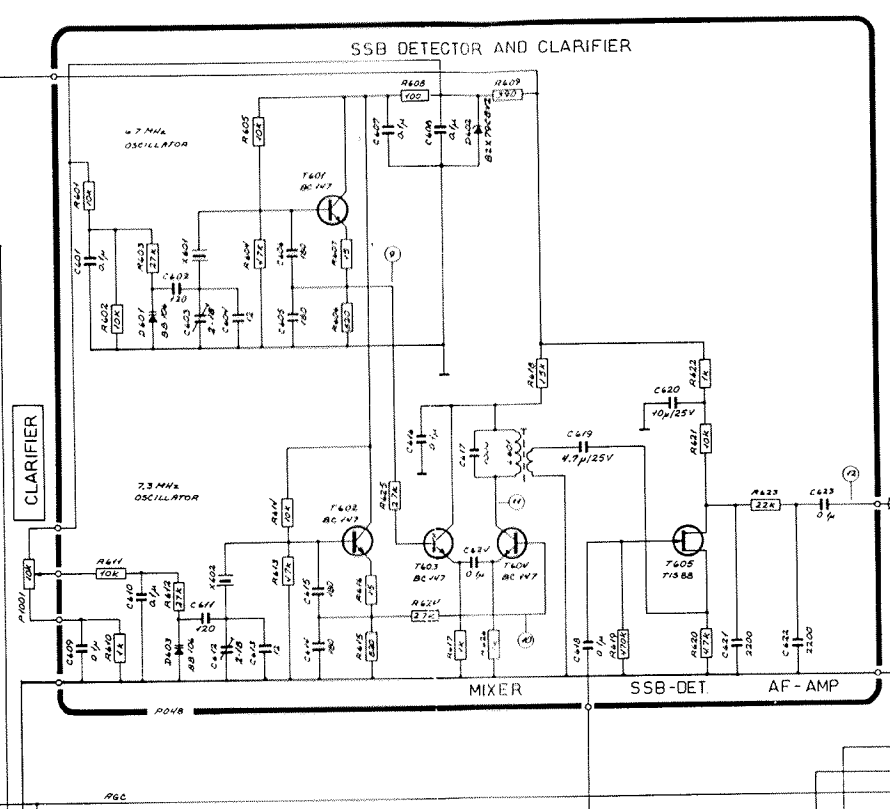
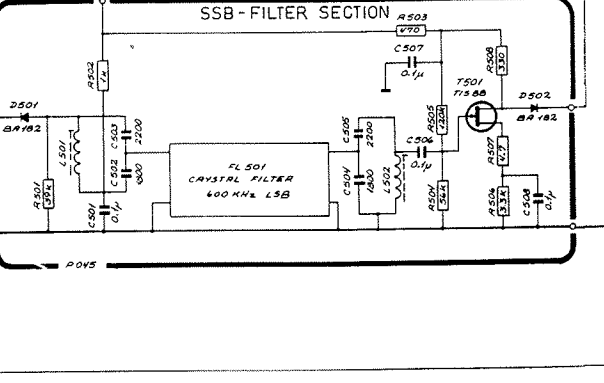
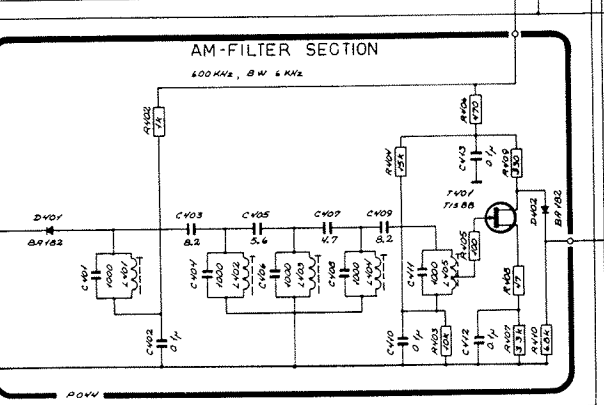
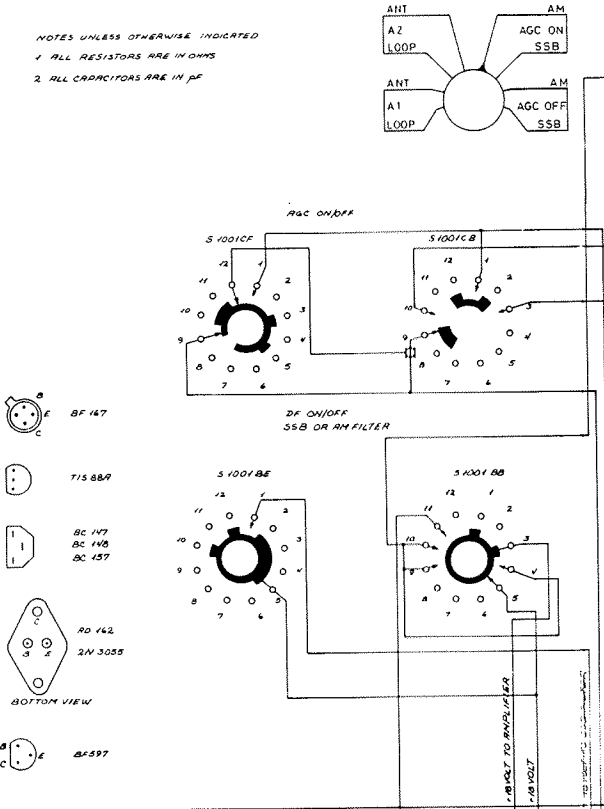
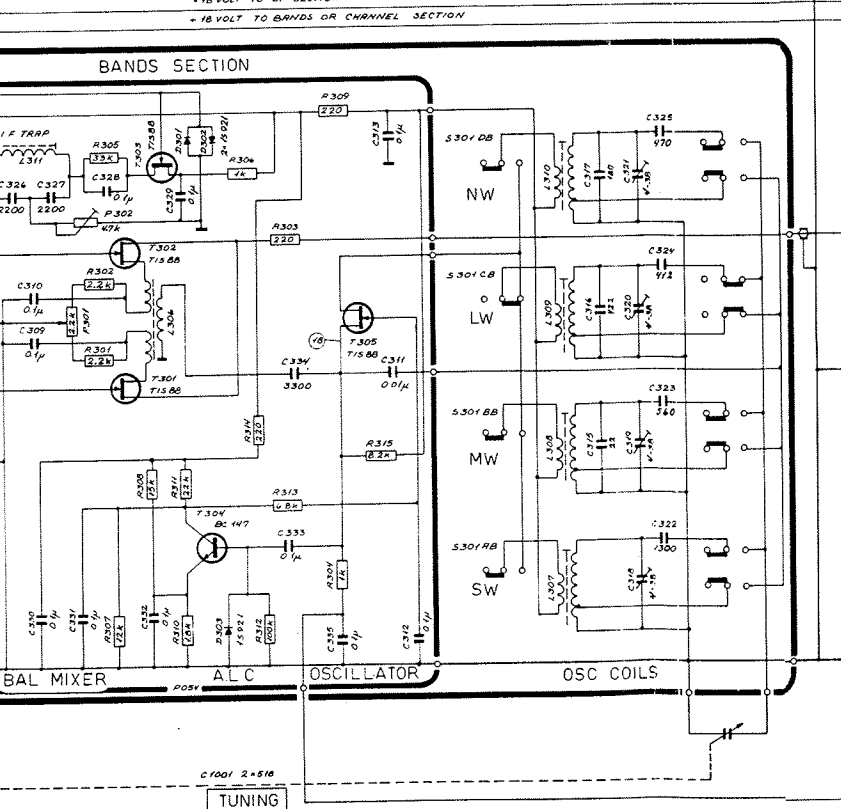
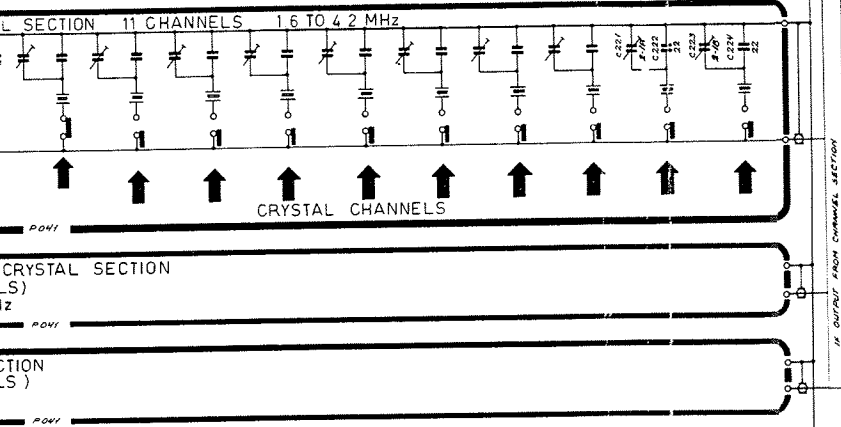
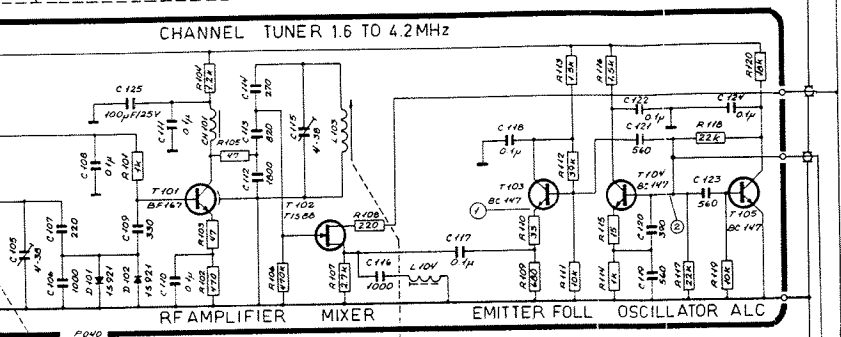
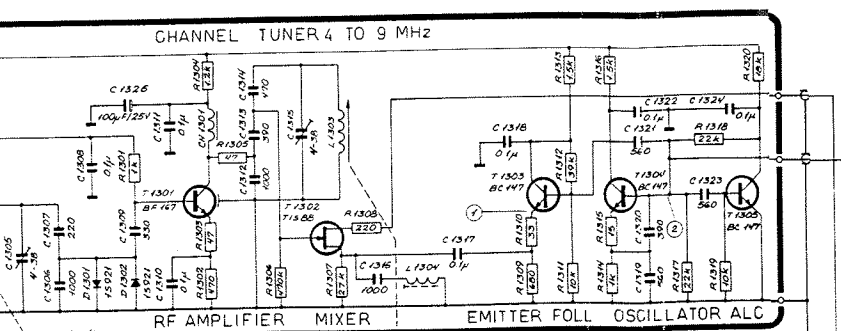

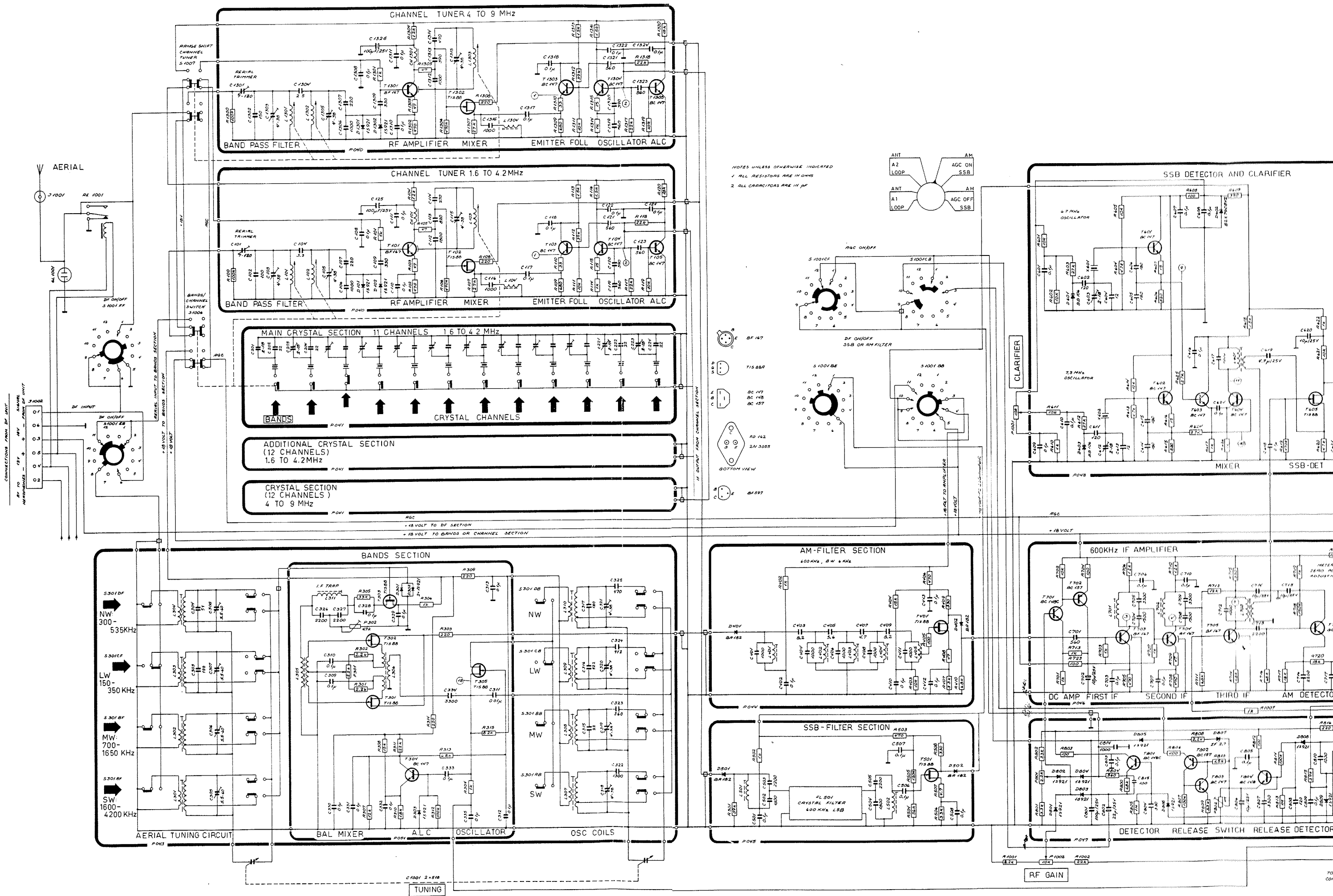

This diagram refers to Sailor R 110